

ABS MARK II BRAKING SYSTEM

Scuola Assistenza

Alfa Romeo 

CONTENTS

	Page
INTRODUCTION	1
OPTIMUM BRAKING	3
ALFA ROMEO ABS	5
OPERATING PRINCIPLE	7
System self diagnosis	7
Behaviour when braking	10
Advice on the precautions to take when using the ABS MARK II SYSTEM	14
ELECTROPUMP UNIT AND ACCUMULATOR	15
BRAKE FLUID TANK	18
HYDRAULIC ASSEMBLY	20
Brake activated without ABS control system	23
Brake activated with ABS control system	25
IMPULSE PICK-UPS	26
ELECTRONIC UNIT	28
ABS DIAGNOSIS	31

INTRODUCTION

During the first half of this century the introduction of the novel hydraulically activated braking systems gave rise to the pursuit of safety improvement and a reduction in car braking distances. As the hydraulic control system alone made possible certain improvements such as the even transmission of braking power to all four wheels, not to mention prompt activation, so did the disc brakes bring about a distinct development as regards safety levels. The latter solution, in fact, meant a drastic reduction in the instances of drifting and fading of braking action under stress, both these situations being typical where drum brakes are concerned.

Moreover, still on the subject of safety, the first systems equipped with brake pressure, devised to prevent the rear wheels from locking before the front ones, came into being, thus allowing greater vehicle road holding to be achieved when braking. Notwithstanding these improvements and those to follow, these braking systems were still far from providing ideal performance levels.

In fact, depending on the road surface and the pressure exerted on the brake pedal, the wheels inevitably tend to lock with consequent loss of vehicle control. This is due to the fact that a locked wheel cannot absorb the side forces exerted on the tyre; steering capacity is therefore lost. Early in the 70'S, experiments began on a limited number of vehicles equipped with an **ABS** device; that is, a special type of brake system which prevents any of the wheels from locking during braking, whatever the condition of the road surface.

A turning point in the evolution of the **ABS** systems was reached a few years later with the development of microprocessors controlled by electronics. The application of this new technology meant that all the previously unsolved problems which had prevented the assembly of the **ABS** systems on mass produced cars were now overcome. An electronic unit controlled by a microprocessor is capable of achieving the most elaborate management of the input signals deriving from the car wheels as well as extremely precise control of the braking power. A control system engineered in this fashion and applied to hydraulic systems by nature akin to the traditional ones as far as philosophy, weight, dimensions and reliability are concerned, constitutes one of the major safety devices assembled on the most recent models, achieving optimum levels of safety and car handling, whatever the brake action and road surface.

OPTIMUM BRAKING

The introduction hinted at the importance of the fact that the wheels should never lock during braking so as not to impair car stability and handling. Now, let us consider how the tyre should react with respect to the road surface in order to achieve the best possible braking distances.

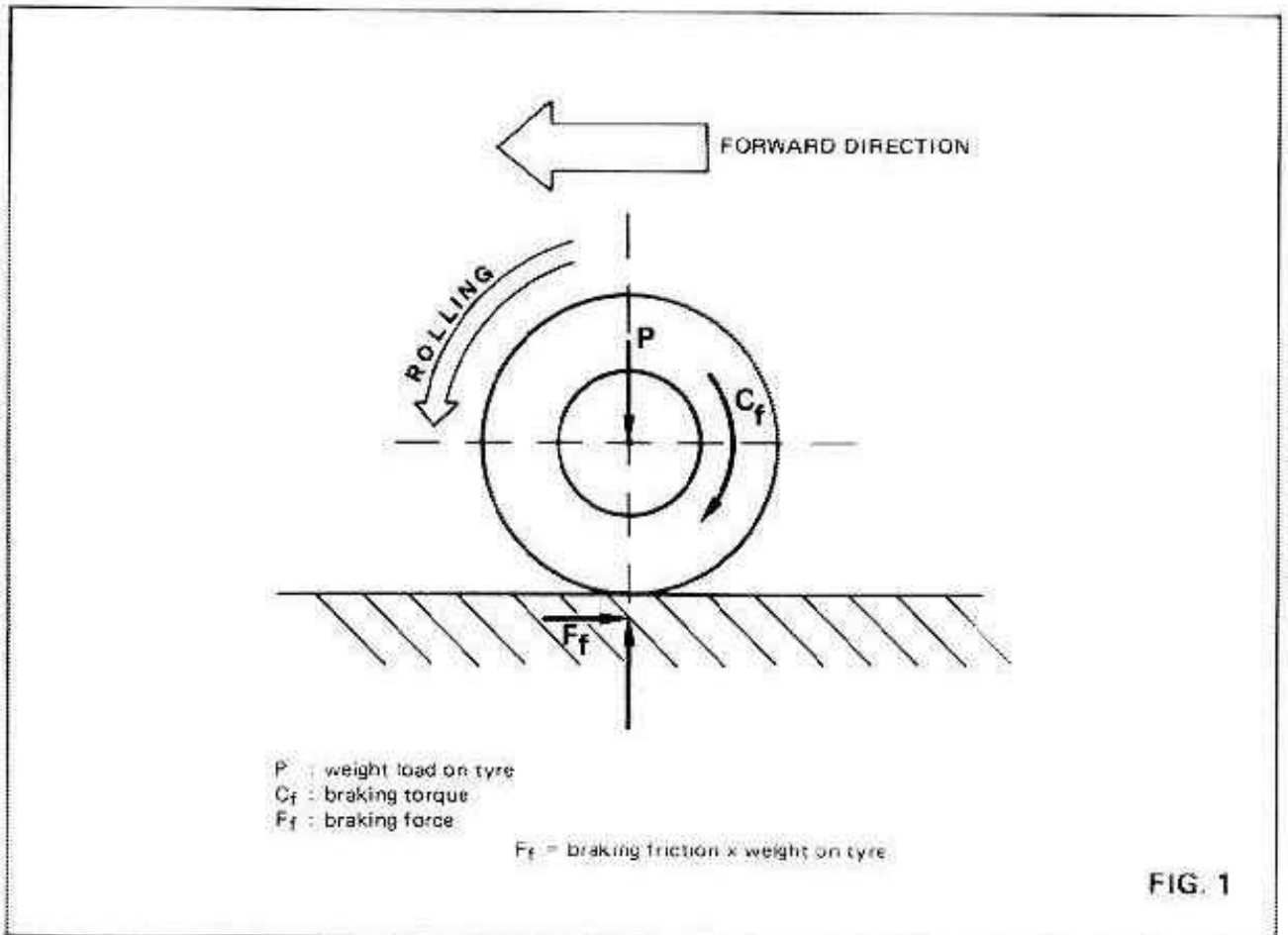

Figure 1 shows the forces affecting a wheel being braked. Note that the braking power is directly proportional to the braking friction coefficient and to the load on the tyre.

Since the latter depends on factors unrelated to the braking system (vehicle weight, shock-absorber condition etc.), it will not be dealt with in this article.

When braking, peripheral speed of the wheels tends to diminish at a rate higher than that of the vehicle speed; as a limit condition, if the wheels lock and the car is still moving the difference between the two speeds is maximum.

This difference in speed is termed **SLIPPAGE**, also known as **SKID CO-EFFICIENT** which represents the percentage value of the difference between the two speeds.

We shall therefore have:

- SKID = 0% if the wheel is free to turn
- SKID = 100% if the wheel is locked and the car in motion

The graph in figure 2 illustrates the evolution of the braking friction in relation to the SKID CO-EFFICIENT.

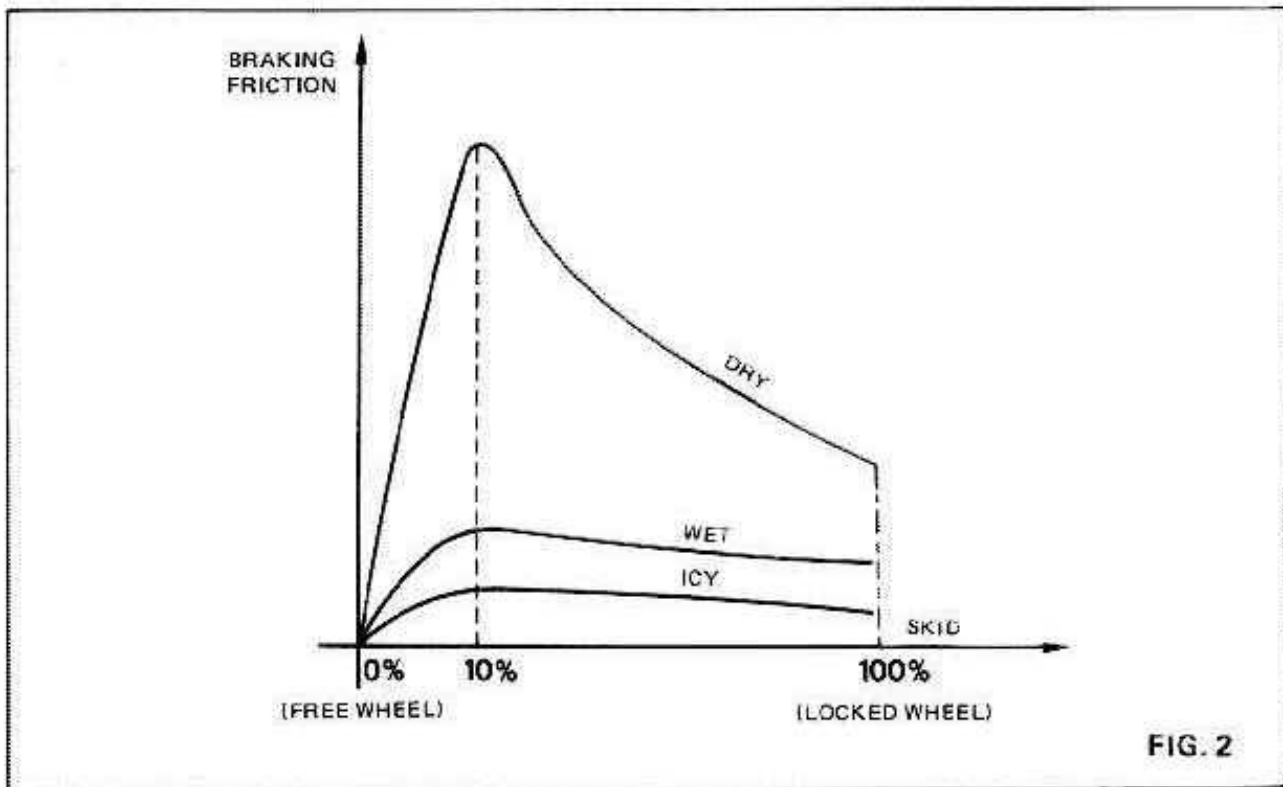

FIG. 2

It may be noted that the braking friction increases distinctly for low skid co-efficient values, and then diminishes gradually as the wheel tends to slow down too much in relation to the speed of the vehicle.

Maximum braking efficiency is therefore attained with a skid co-efficient between the limits of 5% to 15% and, in general, never when 20% is exceeded (see figure 3).

The purpose of the **ABS** device is indeed to modulate the braking pressure so that the skid co-efficient is kept within the optimum values; this enables braking to be accomplished with maximum braking friction and, as a result, the vehicle to be brought to a halt in the least possible distance as permitted by the road surface and tyre conditions.

Any driver, even the most inexperienced, will be able to drive like the best of pilots provided he reacts promptly with determination even when faced by dangerous situations.

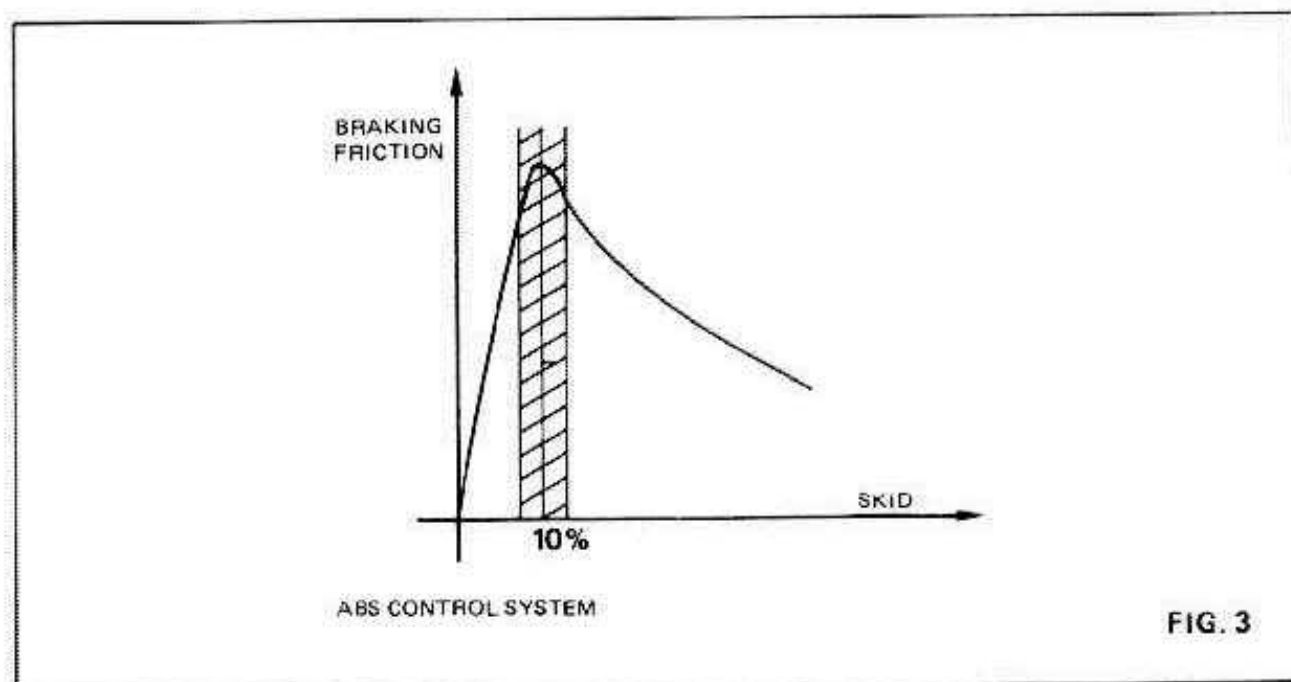
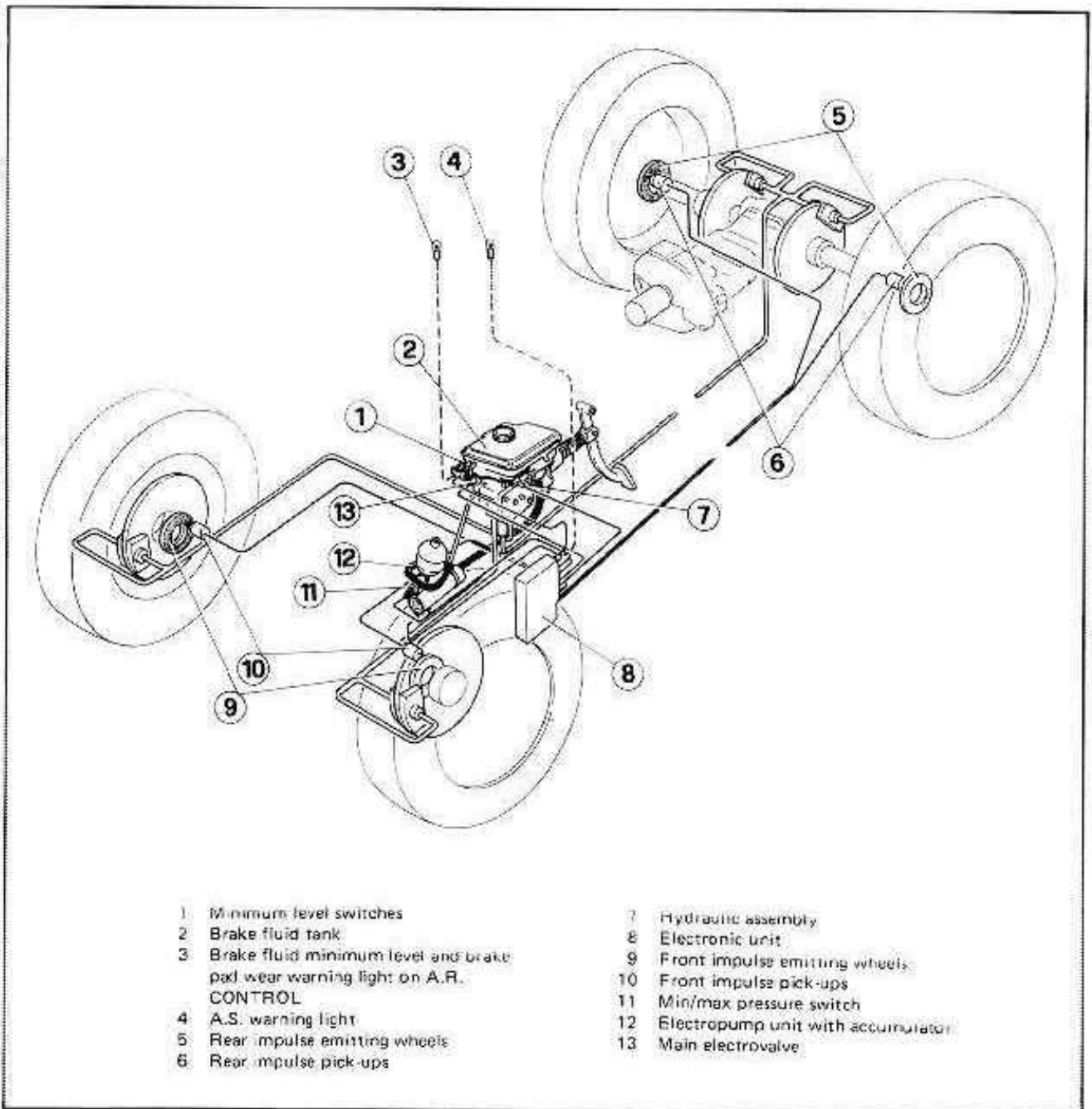

FIG. 3

ALFA ROMEO ABS



After arduous testing both on track and road, the ABS MARK II system manufactured by ALFRED TEVES GmbH is now available on certain models of ALFA ROMEO'S most prestigious cars. The system comprises :

- **HYDRAULIC ASSEMBLY**, made up of a hydraulic servo-brake, a brake pump and electrovalves modulating the pressure at the calipers.
- **ELECTROPUMP UNIT**, made up of a pump driven by an electric motor which maintains the brake fluid in the accumulator at a value of 140 to 180 bar.

- **IMPULSE PICK-UPS**, assembled on each road wheel, which send a frequency that is proportional to the instantaneous speed of the road wheel to the electronic unit via a "IMPULSE EMITTING WHEEL" system.
- **ELECTRONIC CONTROL UNIT**, which represents the intelligent element of the entire system, being capable of processing the input signals and providing the control signals in output.
- **A.S. WARNING LIGHT**, assembled on the instrument panel, indicating the automatic disconnection of the ABS control on detection of a failure in the system.
- **ELECTRICAL SYSTEM**, which, besides the various connections, includes some relays which fulfil different functions.

OPERATING PRINCIPLE

SYSTEM SELF DIAGNOSIS

When the ignition key is turned to IGNITION, power is supplied to the electric circuit of the pump, which builds up and maintains a pressure of 140 to 180 bar in the brake fluid accumulator. The minimum and maximum values are detected by the sensor in the pressure switch which has direct control of the pump relay (see figures 1 and 2).

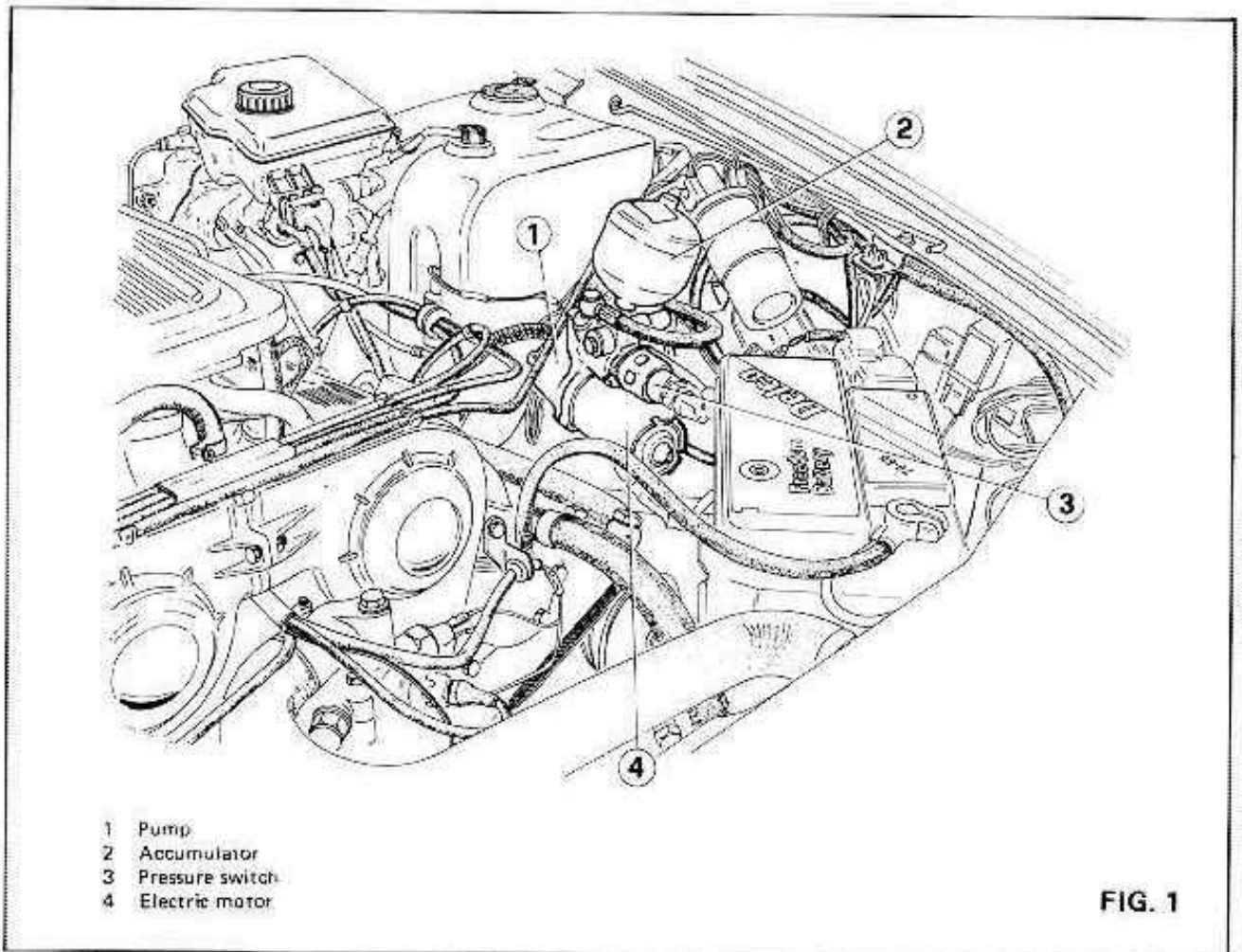

Moreover, as the key is turned, the A.S. warning light illuminates momentarily. During this period of time the electronic unit carries out an initial test on the electrical and hydraulic systems, extinguishing the indicator after 2 seconds only if all has proved efficient.

The power supply to the electronic unit is cut off by means of the relay (see figure 2) when the car is started in order to prevent damage to the unit.

Following this, the A.S. indicator lights again, to extinguish approximately 2 seconds after the key returns from the START to the IGNITION position, that is to say after further diagnosis of the system.

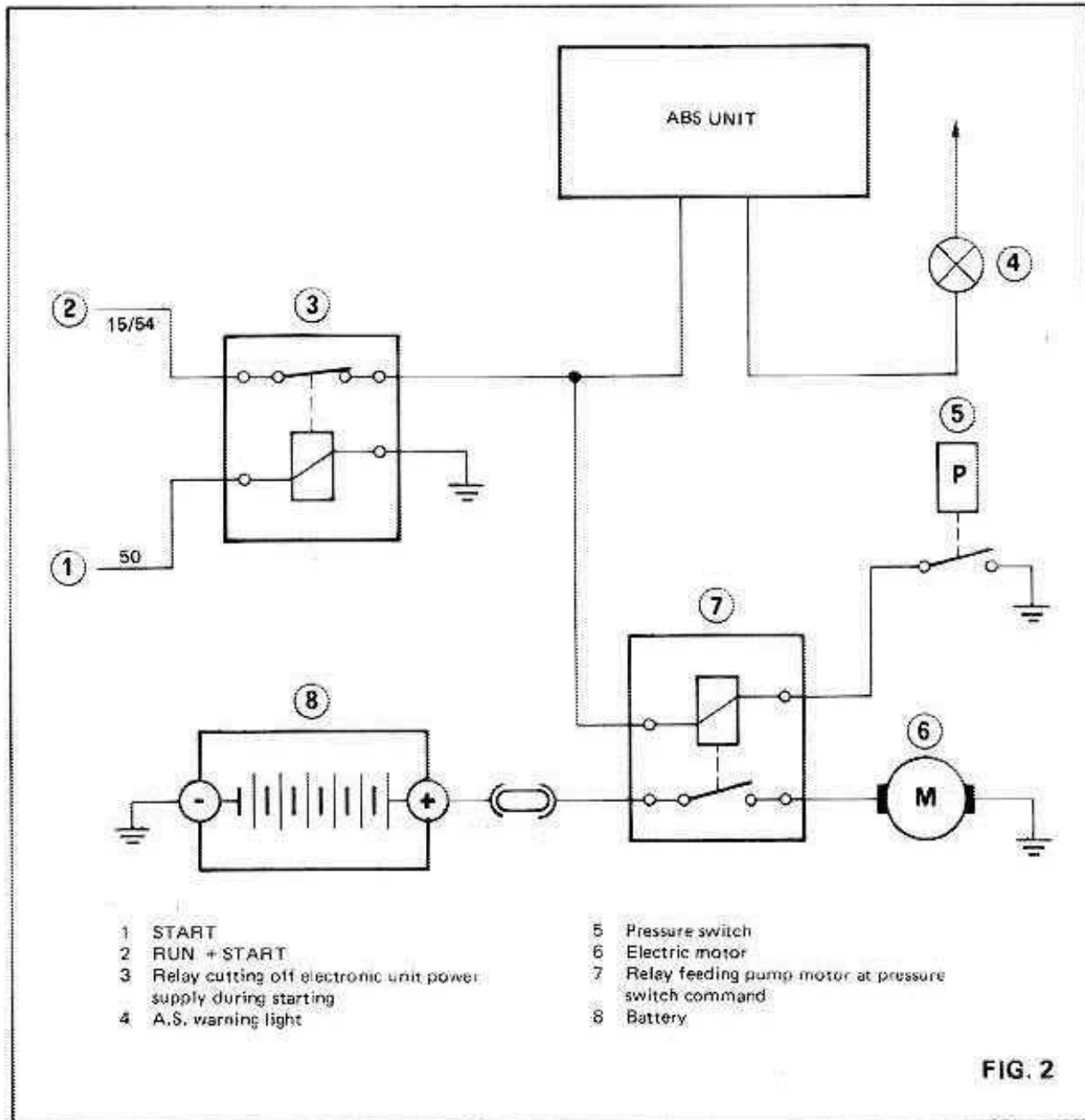

FIG. 2

When running, the unit carries out more tests on the system to check its efficiency and, depending on the conditions encountered, various situations may arise:

- ABS control system active if all tests are positive.
- ABS control system partially disconnected if the failure does not affect the entire system.

- ABS control system completely disconnected if the failure involves the entire system or affects safety when braking.
- ABS control system, partial or total, momentarily disconnected if the failure encountered is temporary.

THE BRAKING SYSTEM BEHAVES LIKE ANY CONVENTIONAL SERVO ASSISTED SYSTEM EVERY TIME THE ABS CONTROL IS DISCONNECTED FOR WHATEVER REASON.

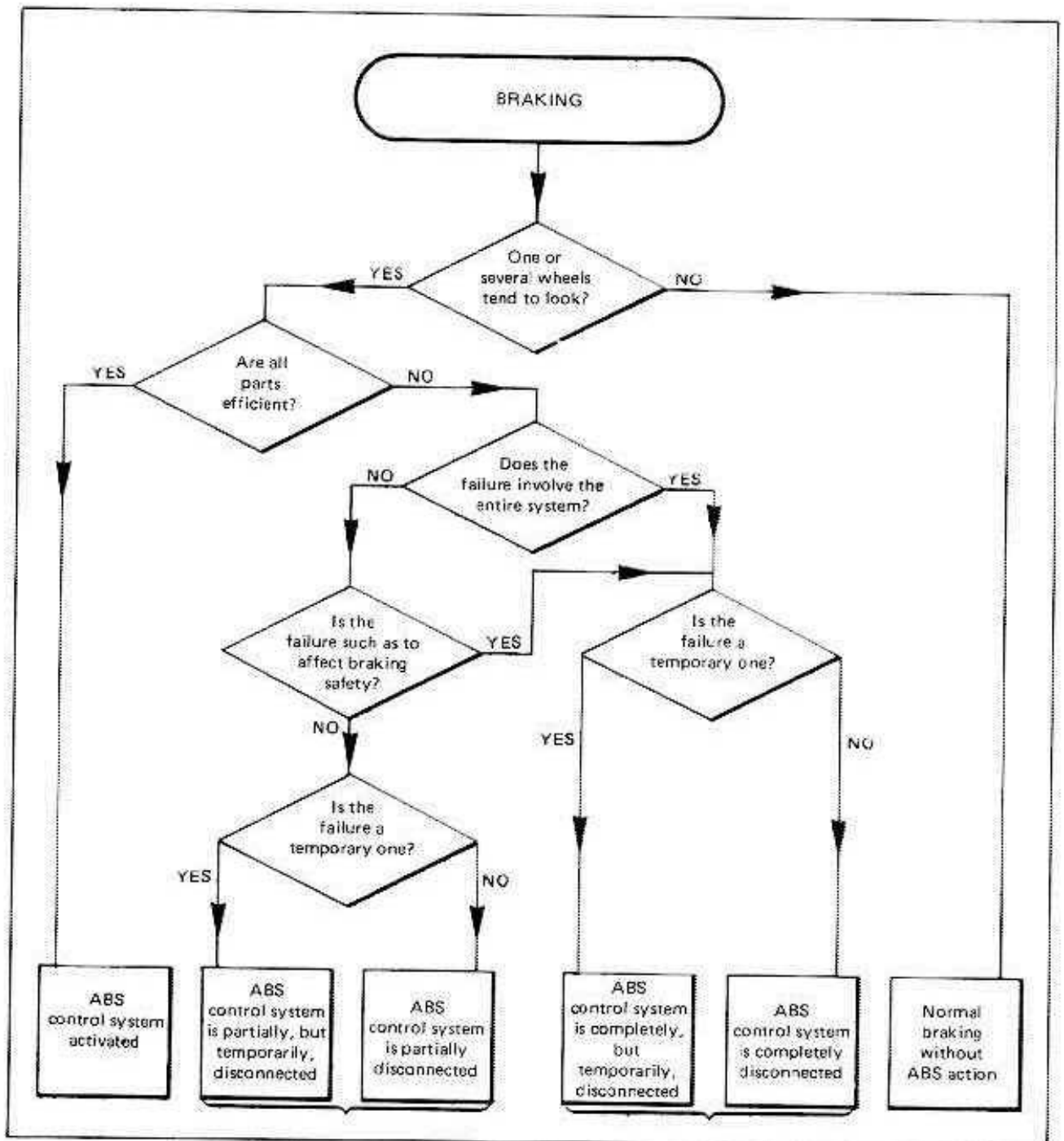

BEHAVIOUR WHEN BRAKING

The braking circuit is the classic type divided into three sections:

- front wheels controlled by separate hydraulic circuits;
- rear wheels controlled by a single hydraulic circuit;

The philosophy of the ABS arrangement is therefore based on the individual control of the front brakes and in accordance with the **SELECT LOW** principle for the rear wheels.

The term **SELECT LOW** means that the electronic unit processes the signals deriving from the impulse pick-ups of the rear wheels separately and carries out adjustment of braking power applied to both wheels according to which one tends to lock, even if this system unnecessarily affects the wheel which is not about to lock. At this point the importance of the reaction of the rear wheels as regards vehicle road-holding during braking should be emphasized. For this reason, any failure whatsoever affecting the rear circuit leads to the complete automatic disconnection of the ABS control system.

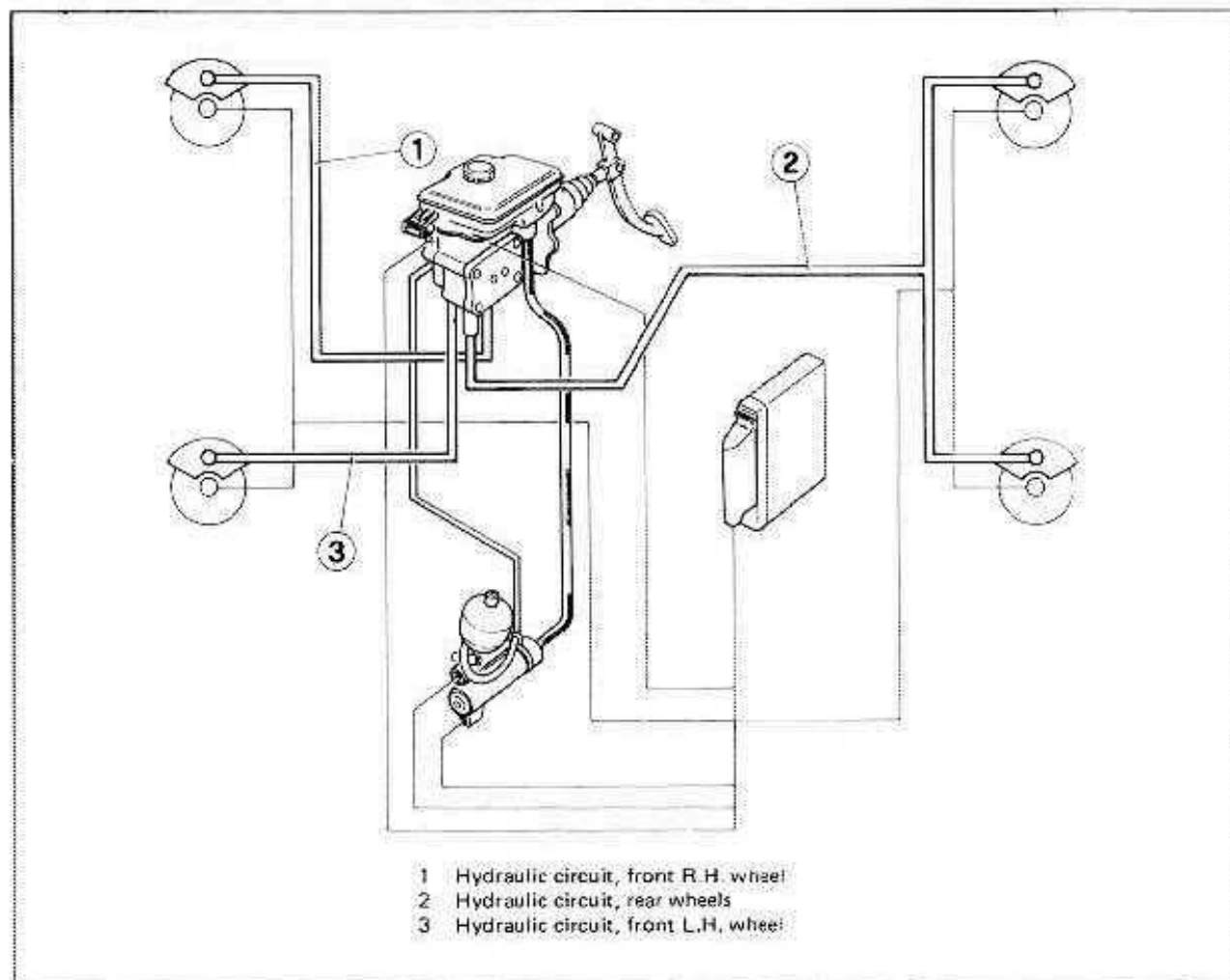

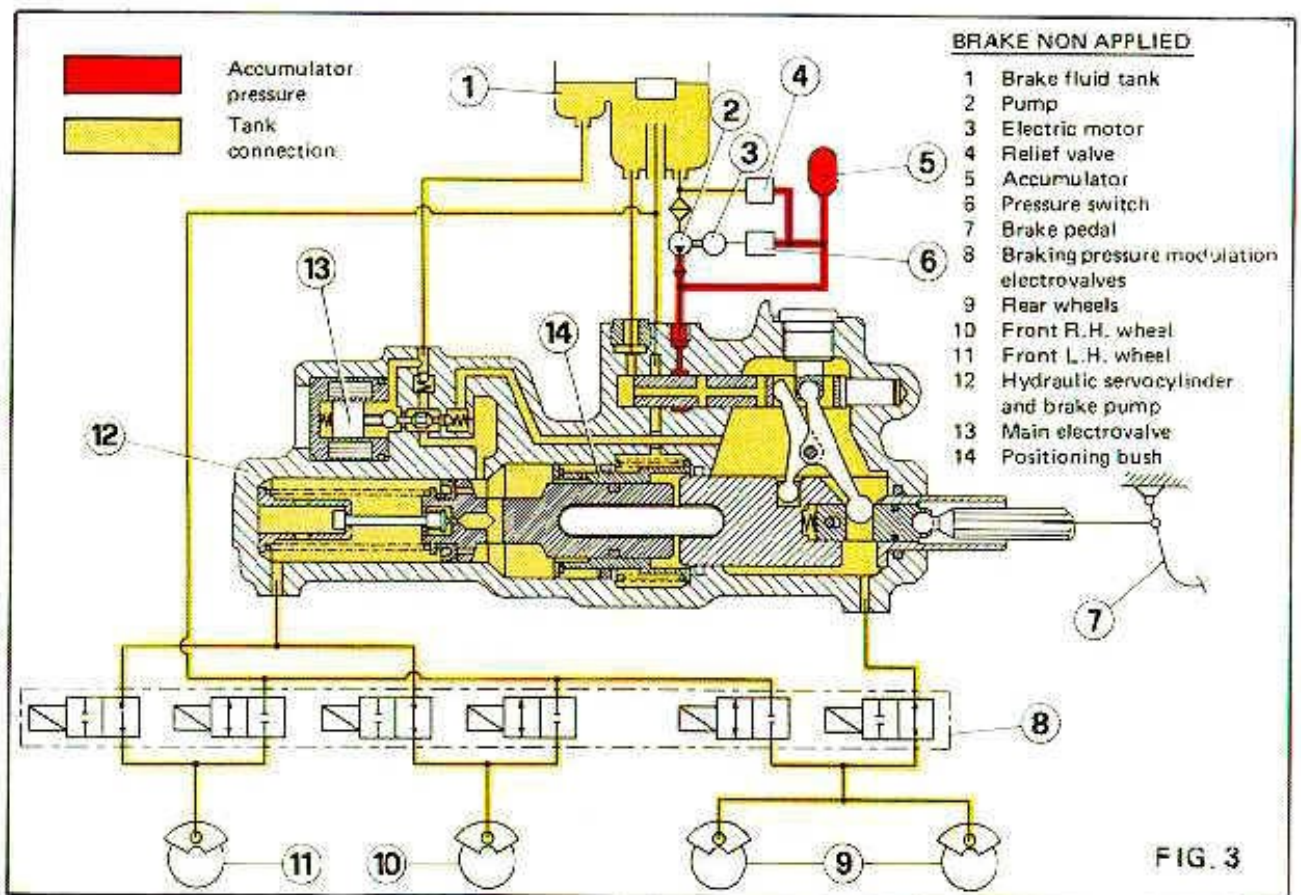

BRAKING WITHOUT ABS ACTION

During normal braking the ABS control system is not activated in as much as none of the wheels decelerates at such a rate as to be interpreted by the electronic unit as a tendency to lock. Braking therefore occurs as a normal servo assisted action.

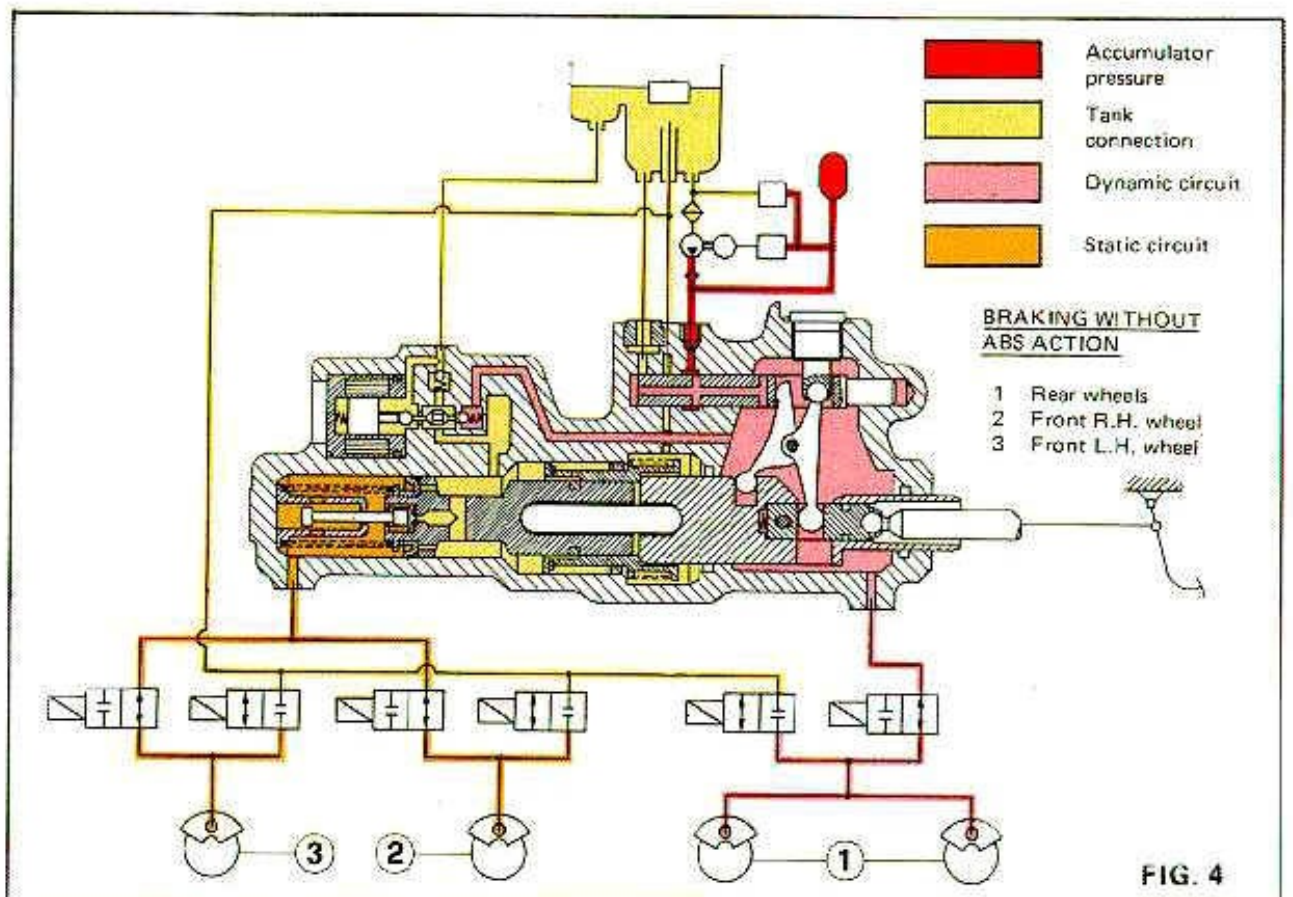

BRAKING WITH ABS ACTION

In the event of emergency braking or of slippery asphalt, on the other hand, ABS control system acts on the wheel that tends to lock, as illustrated in figure 5.

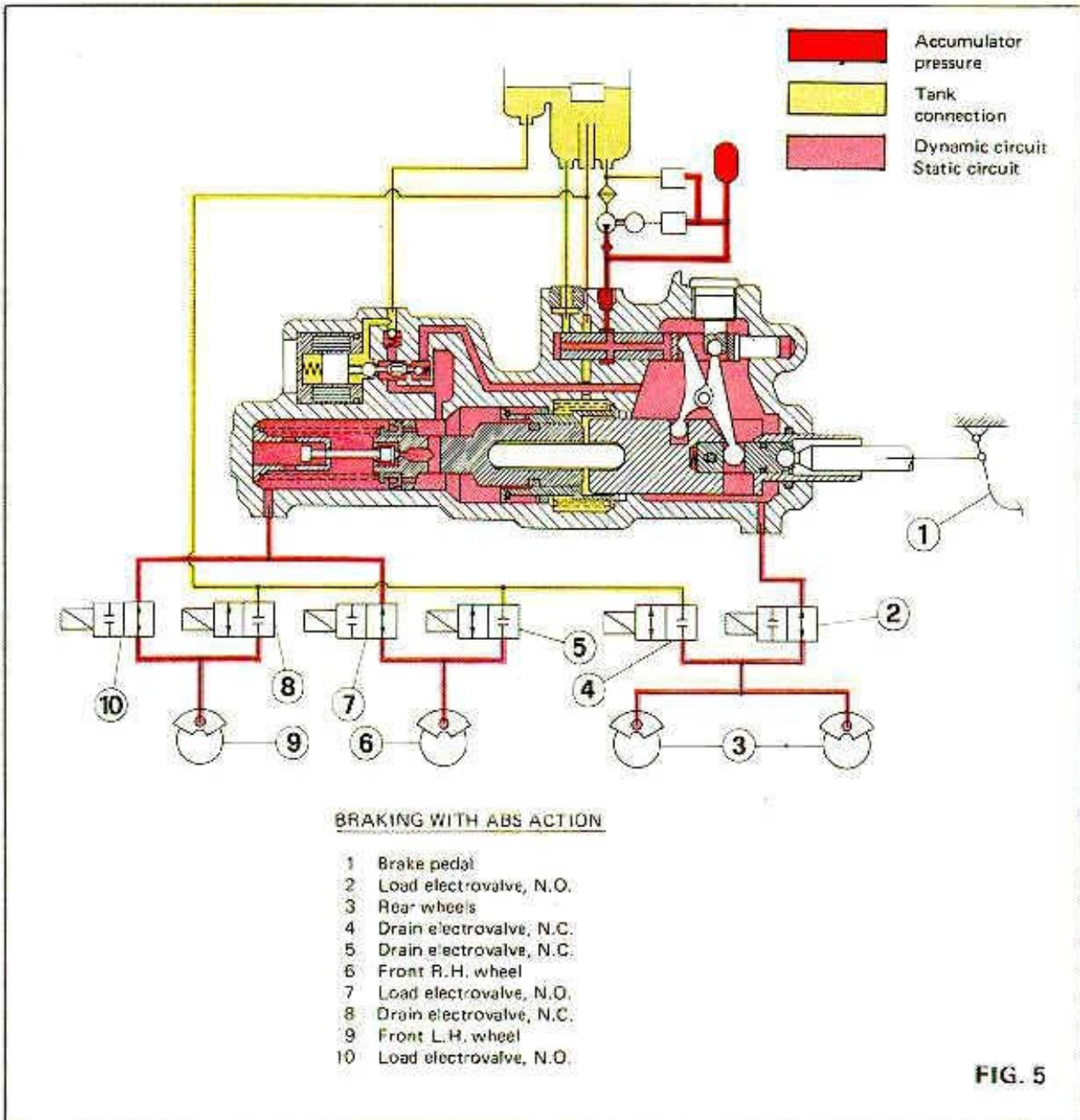

Each braking circuit is composed of a loading electrovalve (see figure 6a) which allows the fluid under pressure to pass to the brake calipers, and from a drain electrovalve (see figure 6b) which allows the fluid to return to the tray, thus reducing the excessive braking pressure.

On activation of the brake pedal, a pressure which is proportional to the force applied is transmitted to the brake calipers by means of the loading electrovalves, which are normally open. This starts off a deceleration of the wheels up to the point where, on the basis of complex calculations, a tendency to lock is acknowledged by the electronic unit.

The loading electrovalve of the circuit involved is closed immediately, while the corresponding drain electrovalve is opened at intervals determined by the unit.

This condition will persist until a re-acceleration, at a fixed value, of the wheel takes place.

At this point the loading electrovalve is opened again by impulse and for brief intervals until the pressure at the calipers is once more on the verge of wheel locking.

The drain electrovalve is subsequently controlled and the cycle repeats itself as long as the brake pedal is activated or until the vehicle comes to a halt.

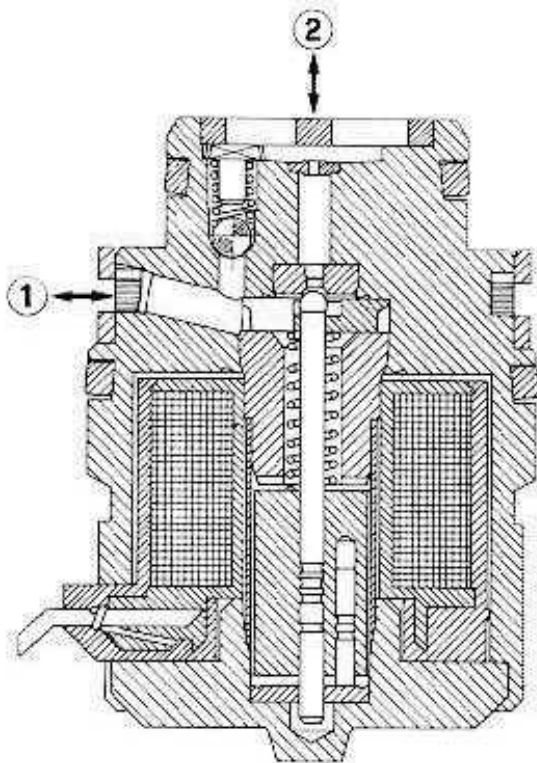

**LOAD ELECTROVALVE
(NORMALLY OPEN)**

- 1 Wheel brake cylinder
- 2 Hydraulic servocylinder and brake pump

FIG. 6a

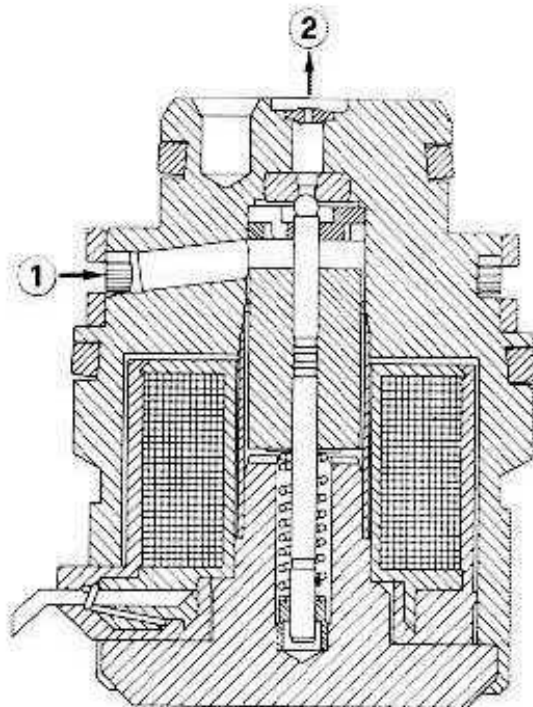

**DRAIN ELECTROVALVE
(NORMALLY CLOSED)**

- 1 Return to tank
- 2 Wheel brake cylinder

FIG. 6b

ADVICE ON THE PRECAUTIONS TO TAKE WHEN USING THE ABS MARK II SYSTEM

When using vehicles equipped with ABS control system, certain fundamental rules should be remembered:

- the fact that the system is available should not induce the driver to run unjustifiable risks;
- driving should be appropriate to road, traffic and atmospheric conditions;
- maximum deceleration attainable depends in all cases on the friction between the tyre and road surface;
- when braking on a road surface liable to cause widely varying conditions as regards the grip on the lateral pairs of wheels it is advisable, wherever possible, not to press the brake pedal down too quickly when starting to brake.

The reason for this is to allow the driver to compensate for the swaying force inevitably created, therefore maintaining the desired direction. It should be noted that in these conditions, any vehicle not equipped with the ABS system would spin around with a risk of serious and inevitable consequences.

ELECTROPUMP UNIT AND ACCUMULATOR

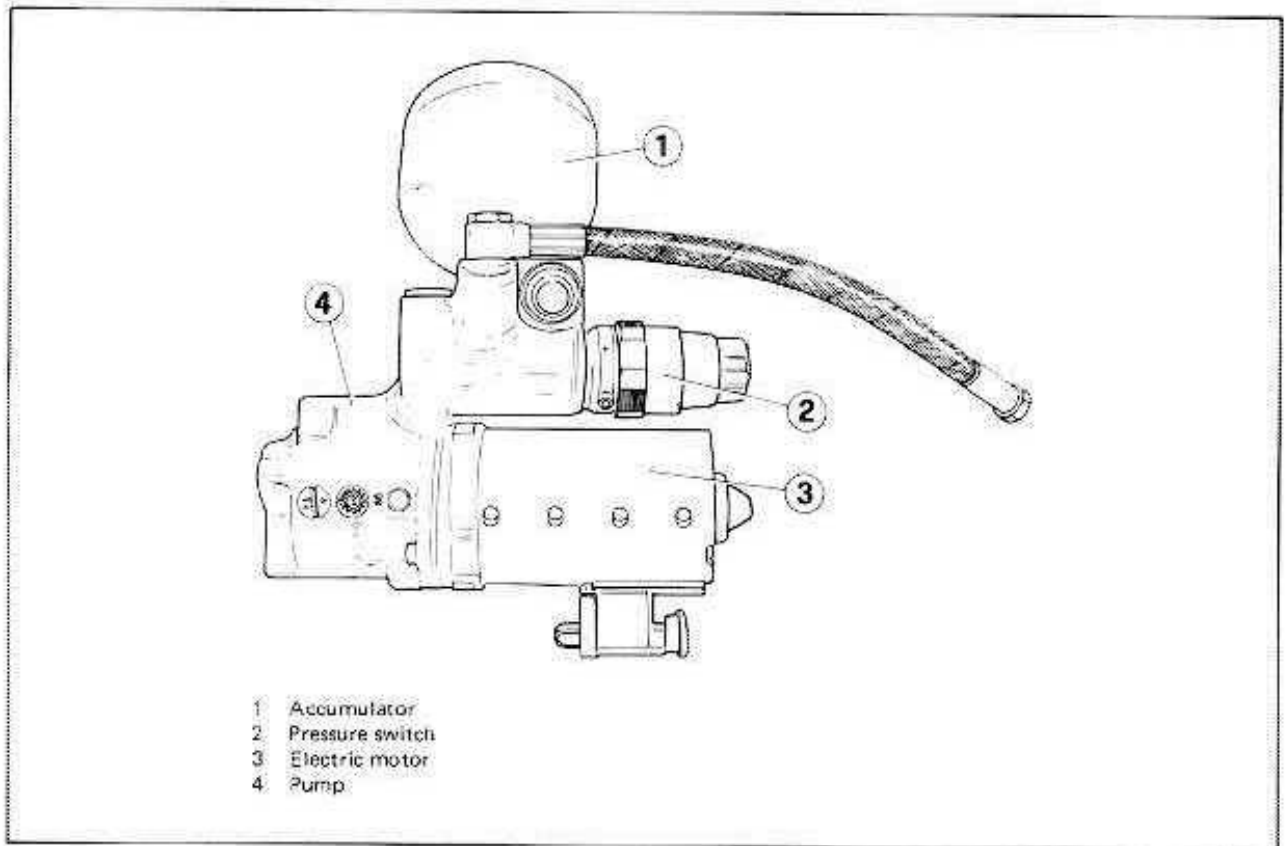

The electric pump makes it possible to bring the brake fluid pressure the accumulator to a value of 180 bar. This pressure, at such a high value, is essential for the achievement of rapid response during ABS control.

When the pressure in the accumulator goes below 140 bar, the pump is automatically enabled. For this purpose there is a pressure switch (see figure 1) made up of three pressure microswitches, the first of which closes at 140 bar and opens at 180, on the high pressure circuit. The first micro switch is used to supply the enable to the pump relay and its task is therefore to maintain the correct pressure in the accumulator.

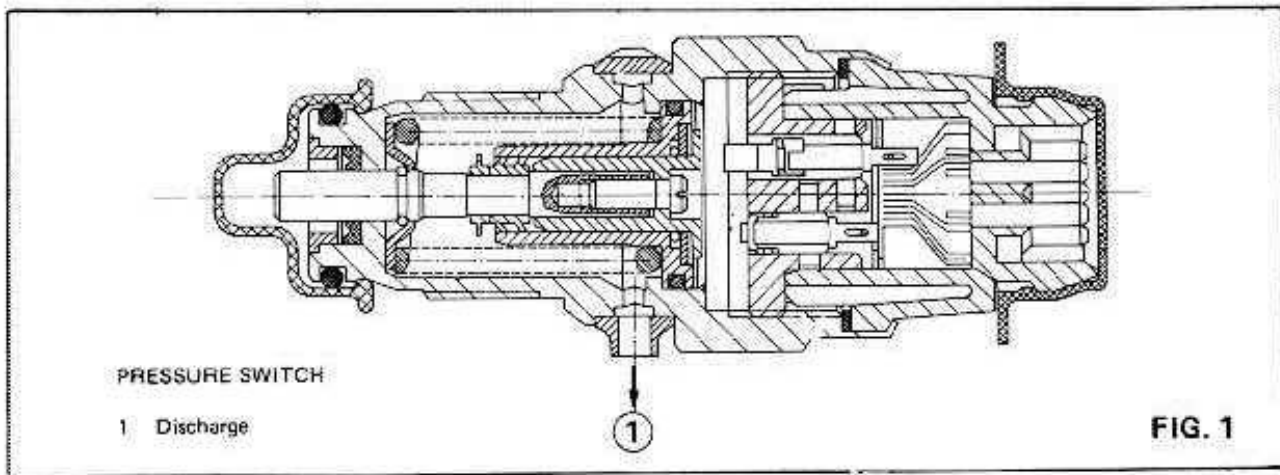

The two remaining microswitches are activated contemporaneous when the pressure goes below the set limit of 105 bar (see figure 2).

Microswitch WS2 causes partial disconnection of the ABS control with consequent illumination of the A.S. warning light on the panel, while WS1 instigates the alarm on **ALFA ROMEO CONTROL**.

Should a momentary failure be responsible for the excessive fall in pressure, WS1 and WS2 will reset once the value of 145 bar has been surpassed.

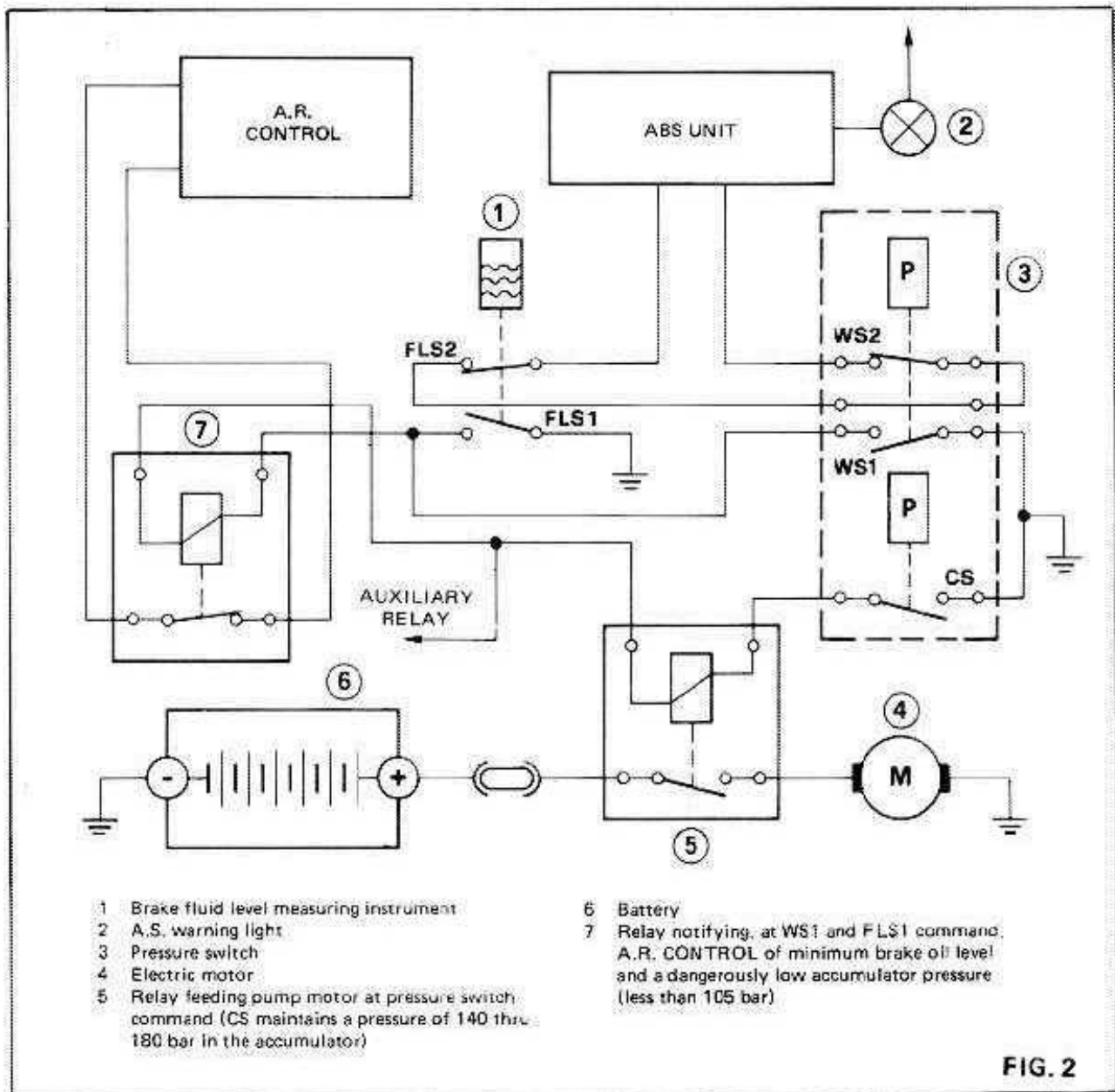

When the pressure in the accumulator is at the alarm pressure limit, several braking actions may still be accomplished, even without ABS control, after which the braking system will be lacking servo-assistance.

To be thorough, it should also be remembered that the accumulator is divided into two sections separated by an elastic diaphragm; one section is preloaded with gas at a pressure of 80 bar, the other at the pressure of the brake fluid (see figure 3). Furthermore, the high pressure circuit is equipped with a safety valve that activates at 210 bar.

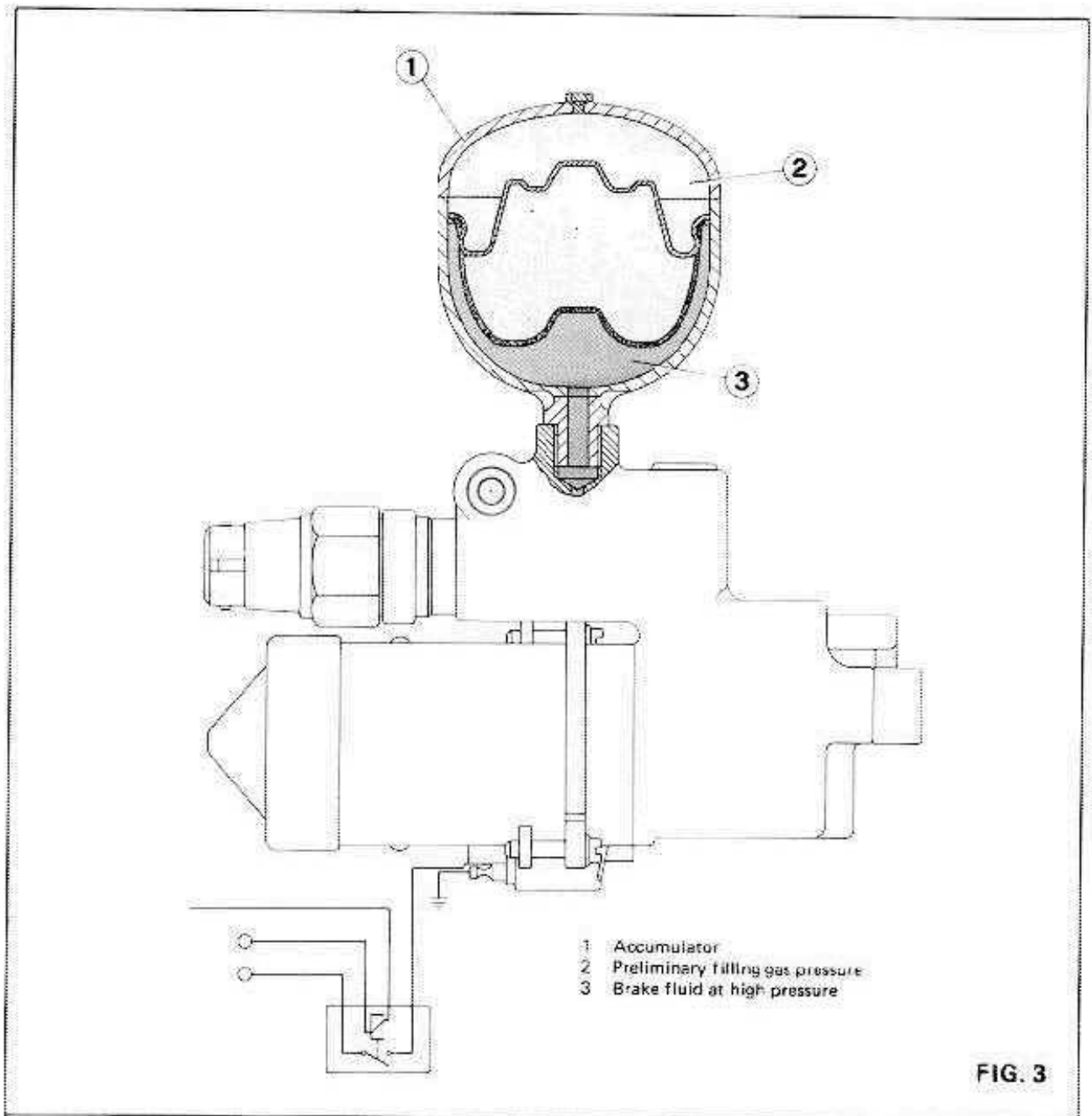

BRAKE FLUID TANK

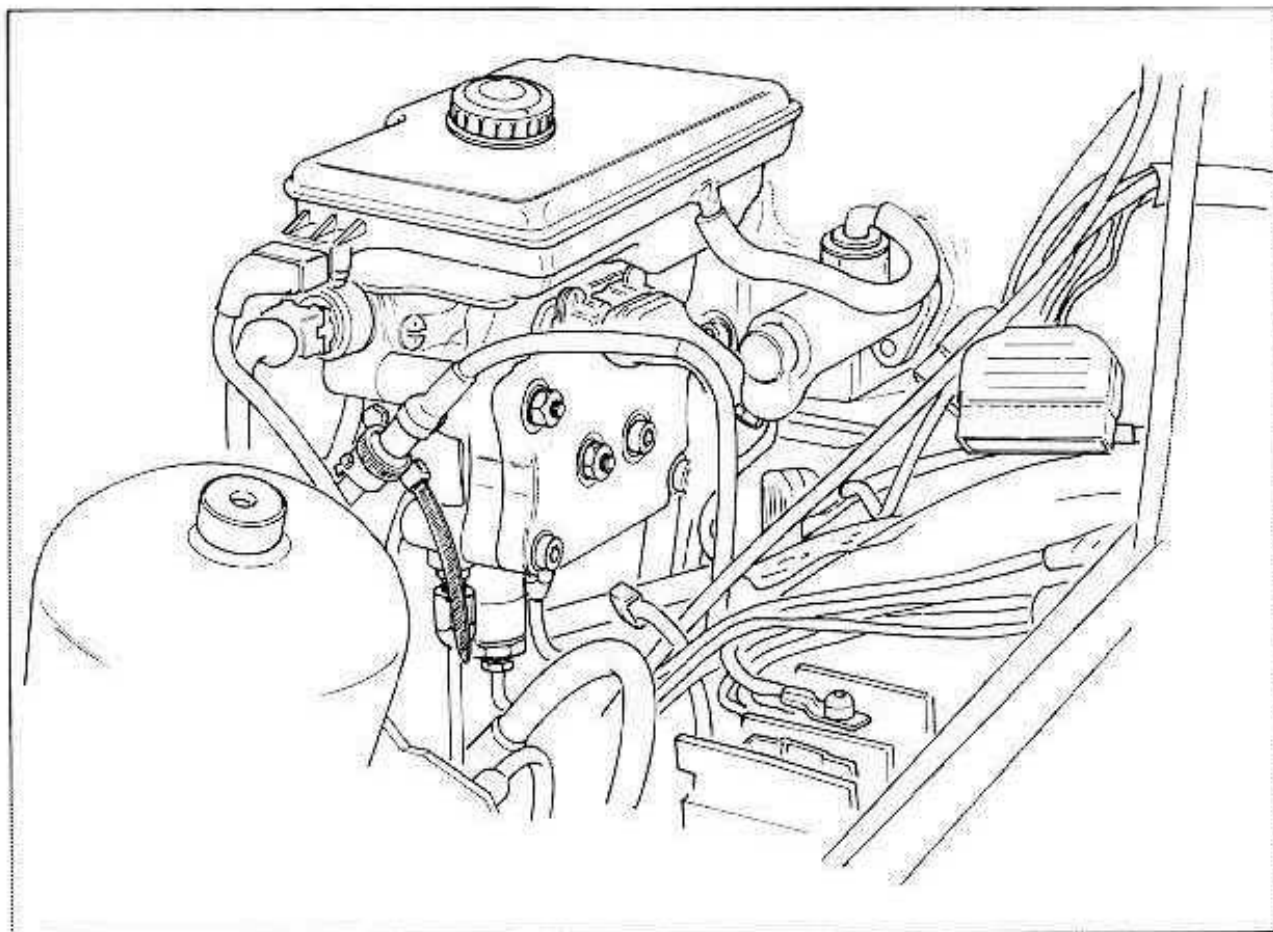

The brake fluid tank (see figure 1) is divided into three chambers:

- 1) supply chamber of the static circuit (front brake circuit);
- 2) supply chamber of the dynamic circuit (rear brake circuit);
- 3) chamber for brake fluid return from dynamic circuit at the end of braking.

The tank also contains a return of brake fluid from the drain electrovalves and a 10 μm filter for the filtering of the fluid sucked in from the electropump unit and accumulator.

There are also two microswitches of the REED SWITCH type activated by a magnet immersed in the float.

The two microswitches are activated at two different levels and provide:

- 1) the minimum oil level signal to the ALFA ROMEO CONTROL;
- 2) danger signal to the electronic unit should the level descend further. On the basis of this signal the unit will partially disconnect the ABS system, that is to say the static circuit (front wheels) adjustment is de-activated and the command to the main electrovalve is inhibited.

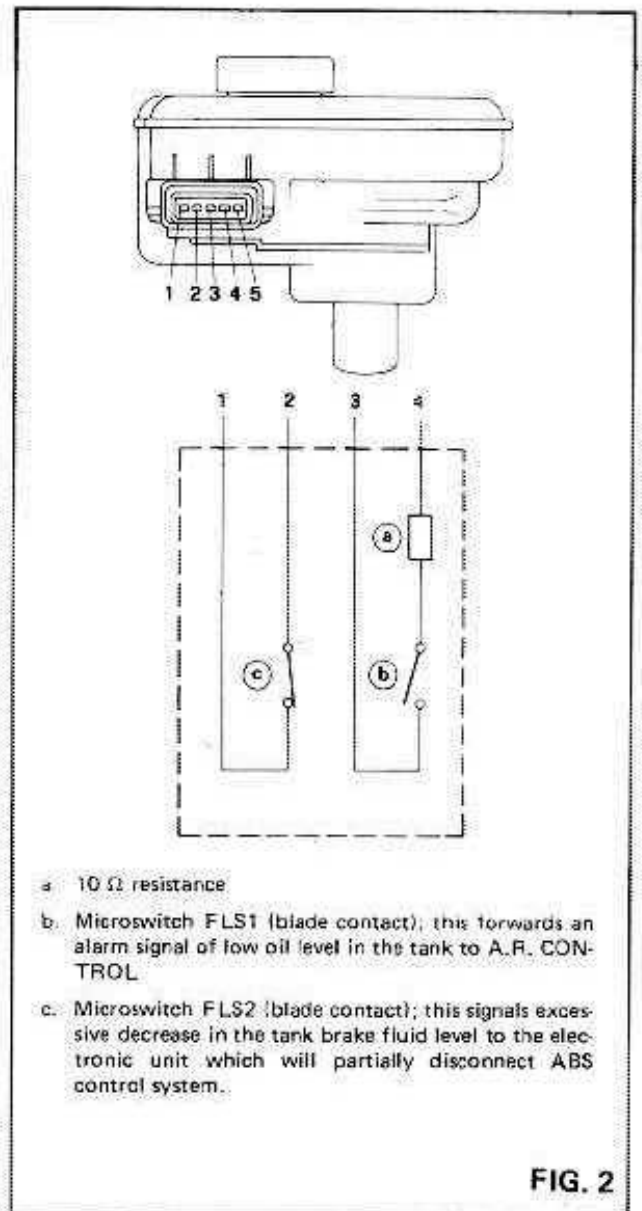
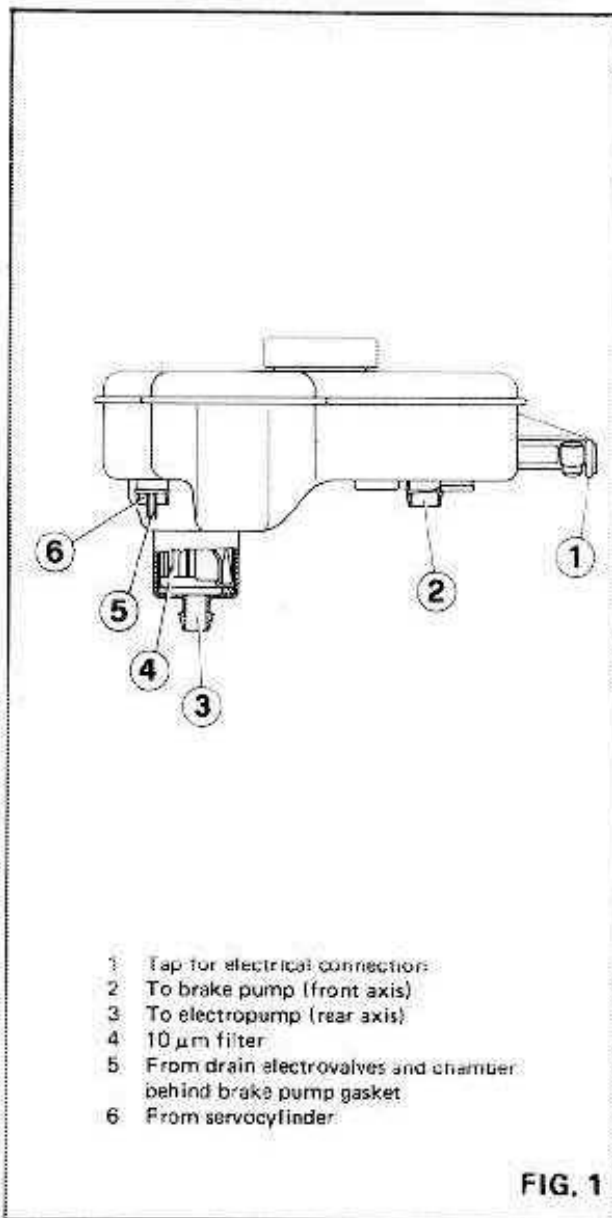

A 10 Ω resistance is placed in series at the first microswitch (see figure 2) and should be taken into account in the event of a continuity check with the OHMMETER.

HYDRAULIC ASSEMBLY

The hydraulic assembly is made up of a hydraulic servo brake to which a brake pump and an actuator containing the electrovalves which allow the ABS control of the braking pressure (see figures 1 and 2) are attached by means of a flange.

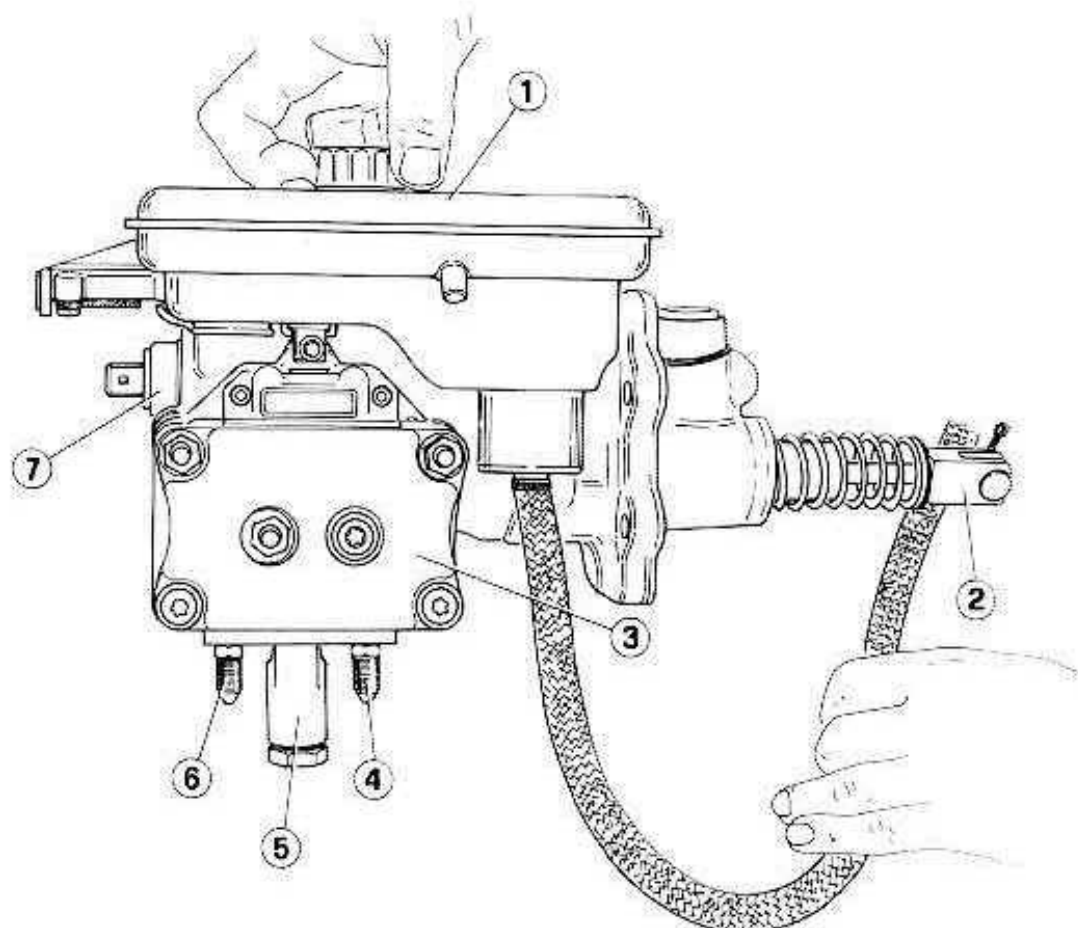

- 1 Brake fluid tank
- 2 Brake pedal attachment
- 3 Electrovalves for braking pressure modulation
- 4 To front R.H. brake caliper
- 5 To rear brake calipers
- 6 To front L.H. brake caliper
- 7 Main electrovalve

FIG. 1

The pressure generated in the servobrake is proportional to the force exerted on the pedal and is directly used to activate the brakes of the rear axis (dynamic circuit). The pressure necessary to the brakes of the front axis, on the other hand, is obtained by means of the brake pump (static circuit). Each of the three braking circuits (two front and one rear) is controlled via two electrovalves : a loading one, normally open and a drain one, normally closed.

In the event of ABS action, the electrovalves are energized accordingly, thus allowing pressure modulation on the wheel in question.

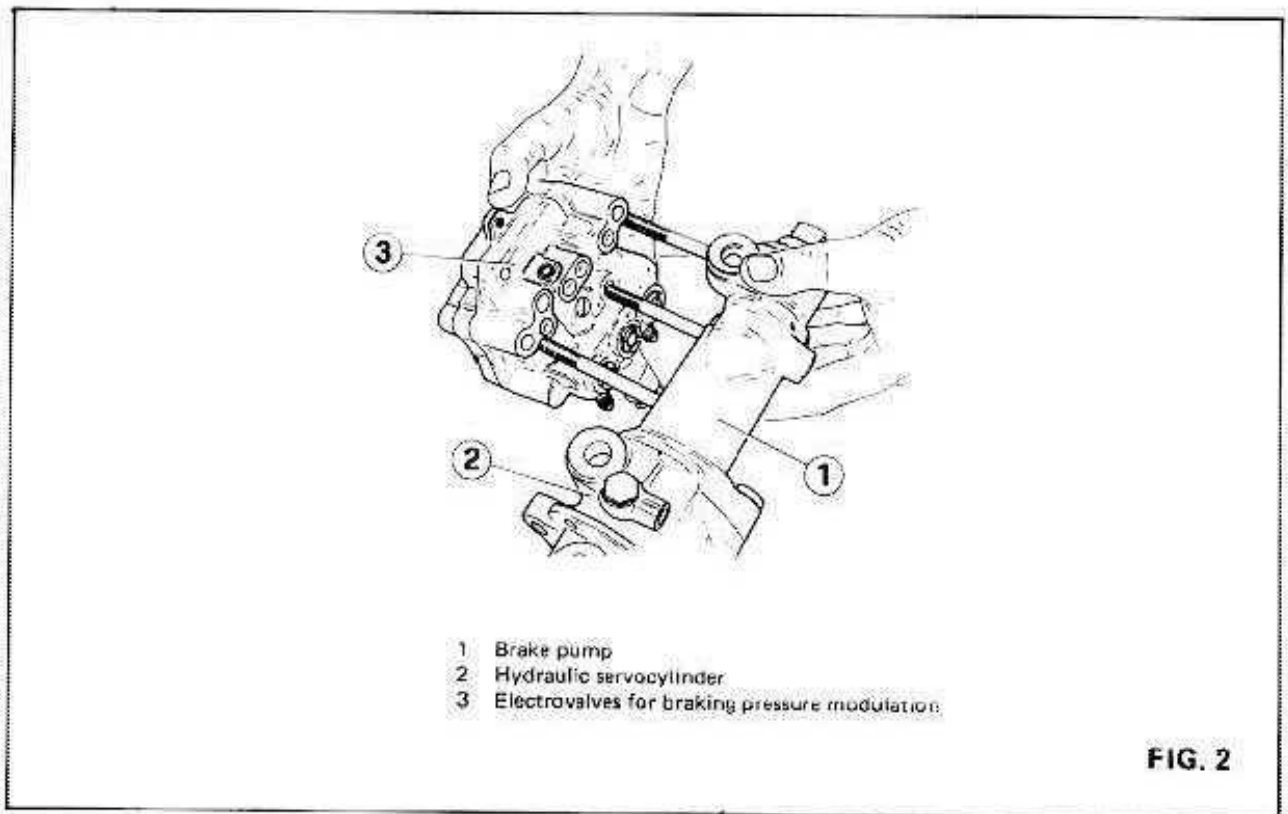

The fluid volumes under pressure which are necessary during ABS system operation in the static circuit (front wheels) are recorder by means of a seventh electrovalve known as the main valve (see figure 3). The purpose of this is to put to the static circuit into communication with the dynamic one, in which there is a pressure proportional to the force exerted on the brake pedal, thus actuating the dynamic supply of the static circuit.

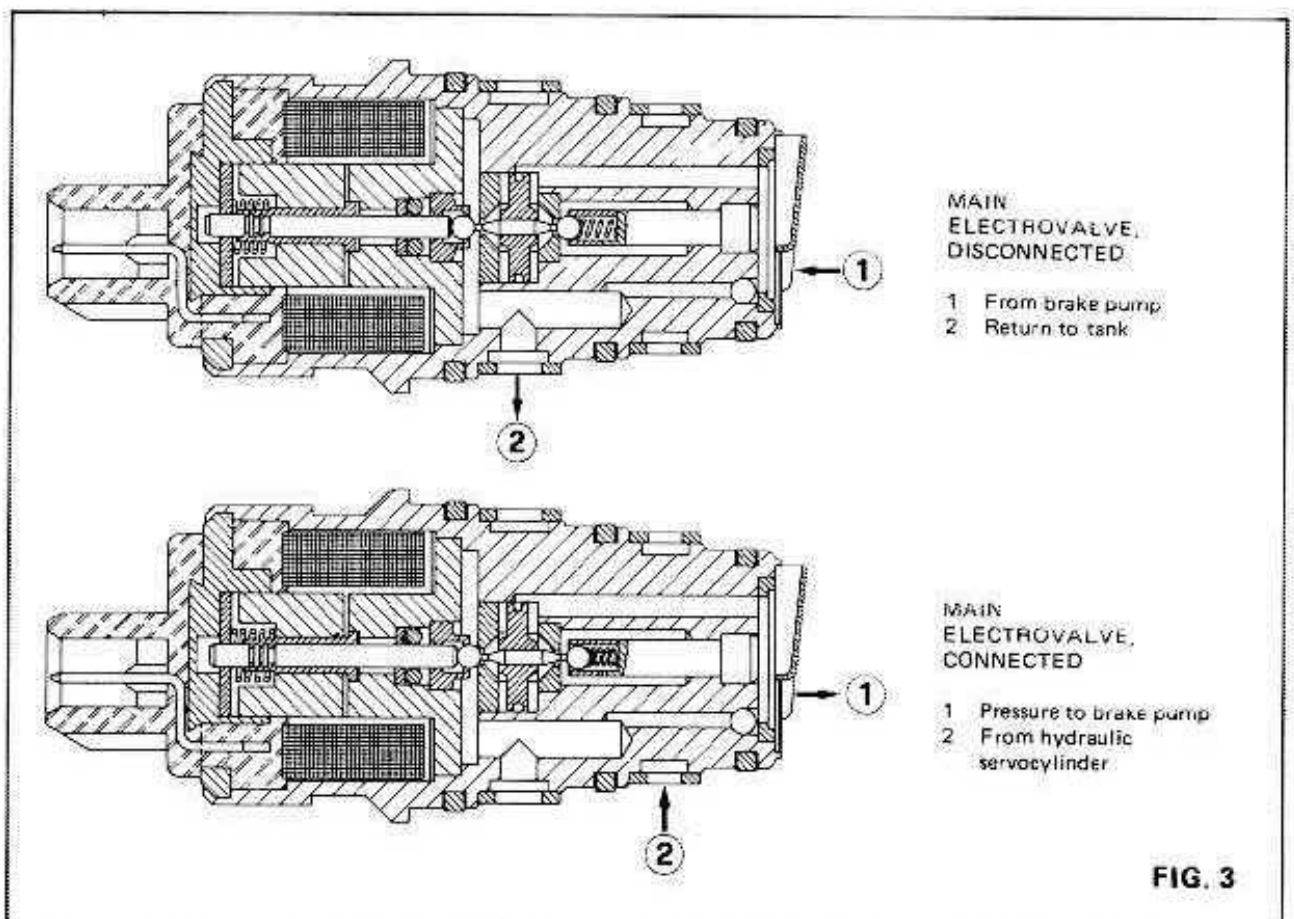

**BRAKE ACTIVATED
WITHOUT ABS CONTROL
SYSTEM**

- 1 Adjusting valve
- 2 Leverage
- 3 Hydraulic servocylinder
- 4 Brake pedal
- 5 Servobrake piston
- 6 Load electrovalve, N.O. (rear wheels)
- 7 Rear wheels
- 8 Front R.H. wheel
- 9 Load electrovalve, N.O. (front R.H. wheel)
- 10 Front L.H. wheel
- 11 Load electrovalve, N.O. (front L.H. wheel)
- 12 Brake pump
- 13 Positioning bush

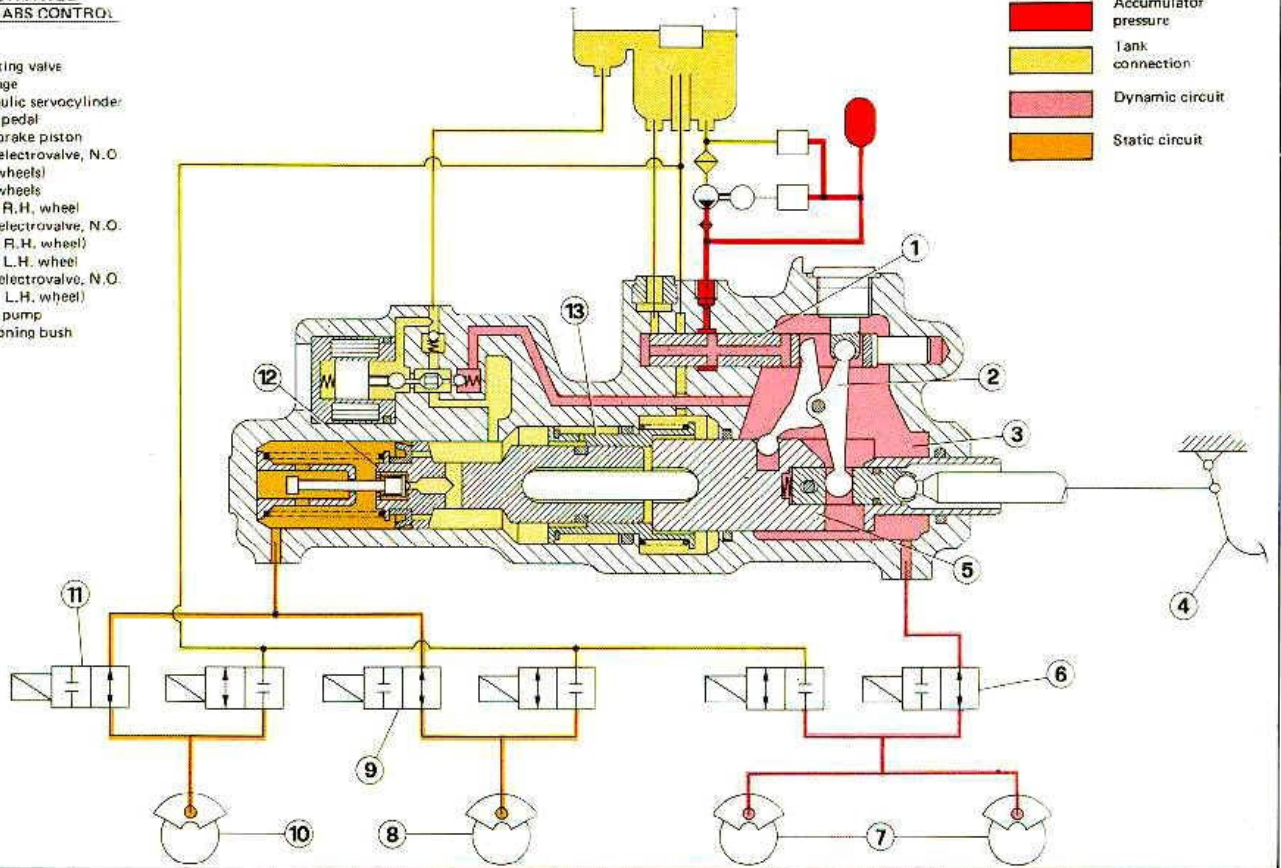
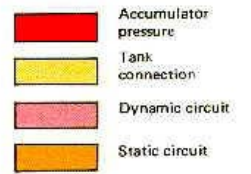

FIG. 4

We shall now consider in detail the operation of the hydraulic assembly in its two possible conditions.

BRAKE ACTIVATED WITHOUT ABS CONTROL SYSTEM

When the brake pedal is pressed, the adjusting valve (1) is controlled by means of the leverage (2), thereby generating in the servobrake a pressure proportional to the force applied to the pedal (see figure 4). This pressure acts on the dynamic circuit and is transmitted by means of the loading electrovalve (6), normally open, to the rear axis. Moreover, the same pressure, acting on the servobrake piston, activates at the same time the brake pump and so a further braking pressure is generated which, by means of the loading electrovalve (9/11), normally open, is transmitted to the front brake calipers.

By increasing the pressure applied to the brake pedal, the servobrake piston beats against the positioning bush (13), dragging it to the left. This does not affect the activation however in as much as the pressure of the spring against the bushing is very slight and therefore imperceptible at the pedal.

**BRAKE ACTIVATED WITH
ABS CONTROL SYSTEM**

- 1 Brake fluid tank
- 2 Brake pedal
- 3 Load electrovalve, N.O.
- 4 Rear wheels
- 5 Drain electrovalve, N.C.
- 6 Drain electrovalve, N.C.
- 7 Front R.H. wheel
- 8 Load electrovalve, N.O.
- 9 Drain electrovalve, N.C.
- 10 Front L.H. wheel
- 11 Load electrovalve, N.O.
- 12 Brake pump
- 13 Main electrovalve
- 14 Brake pump gasket rear chamber
- 15 Positioning bush

	Accumulator pressure
	Tank connection
	Dynamic circuit
	Static circuit

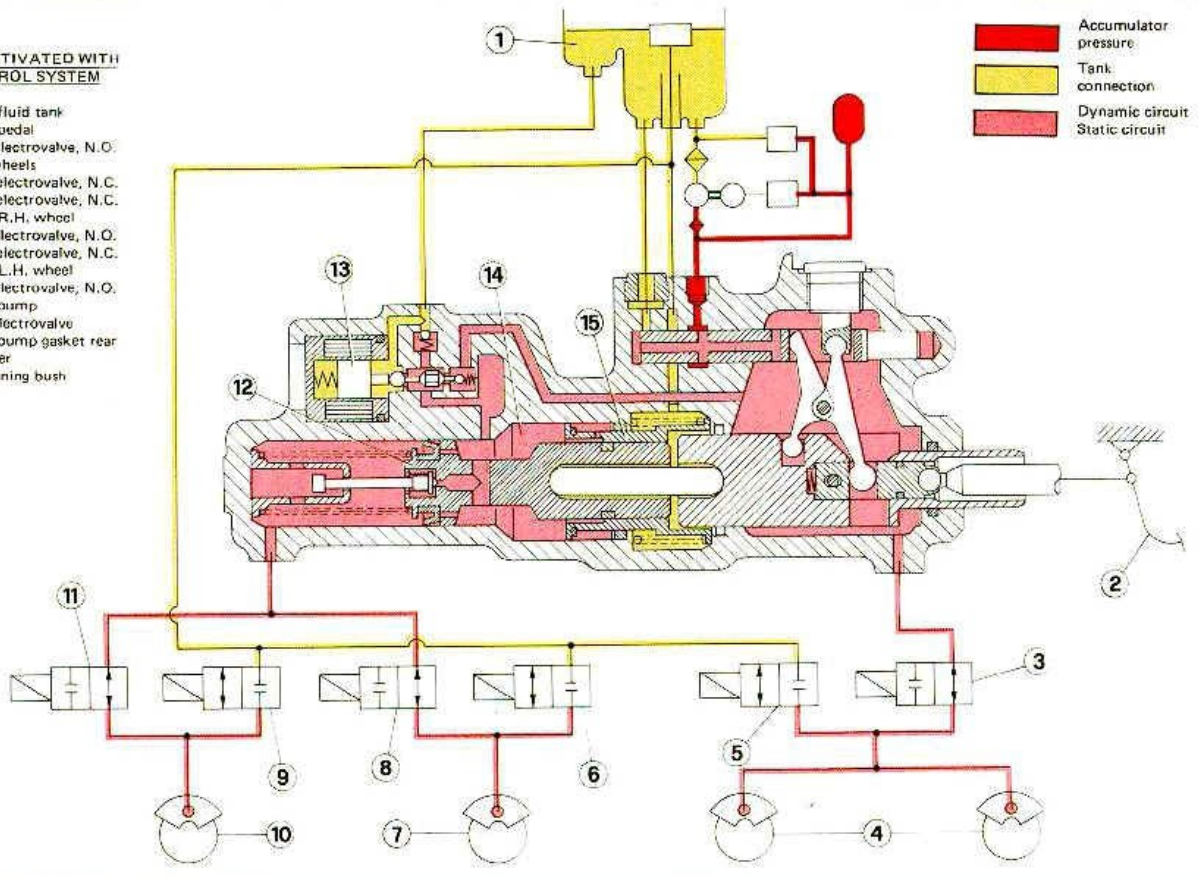

FIG. 5

BRAKE ACTIVATED WITH ABS CONTROL SYSTEM

If, during activation of the braking system, a wheel, at the front, for example, tends to lock, then the associated loading electrovalve closes and the drain one opens. Following this the pressure on the brake caliper decreases, on account of the return circuit to the brake fluid tank being opened.

At the same time the main electrovalve (13) is energized and the dynamic circuit (rear) is connected to the static one (see figure 5). When the wheel being braked starts to regain speed, following the decrease in pressure at the calipers, the drain electrovalve is closed and the loading one opened again. In this way, pressure is gradually restored to the brake calipers by means of the main electrovalve which connects the static circuit to the dynamic one, until the next tendency to lock is detected, at which point the cycle repeats itself.

During ABS control, the pressure in the dynamic circuit also acts on the positioning bush (15) therefore restricting brake pedal travel. This means that, even in the event of a failure during ABS system operation, there is always a certain volume of reserve fluid. ABS control concluded (during or on termination of the braking action), the main electrovalve is de-activated, thus severing the connection between the static and dynamic circuits. Besides this, the chamber (14), at the rear of the brake pump gasket, is reconnected to the tank and the positioning bush de-activated. Normal brake activation is thus restored.

IMPULSE PICK-UPS

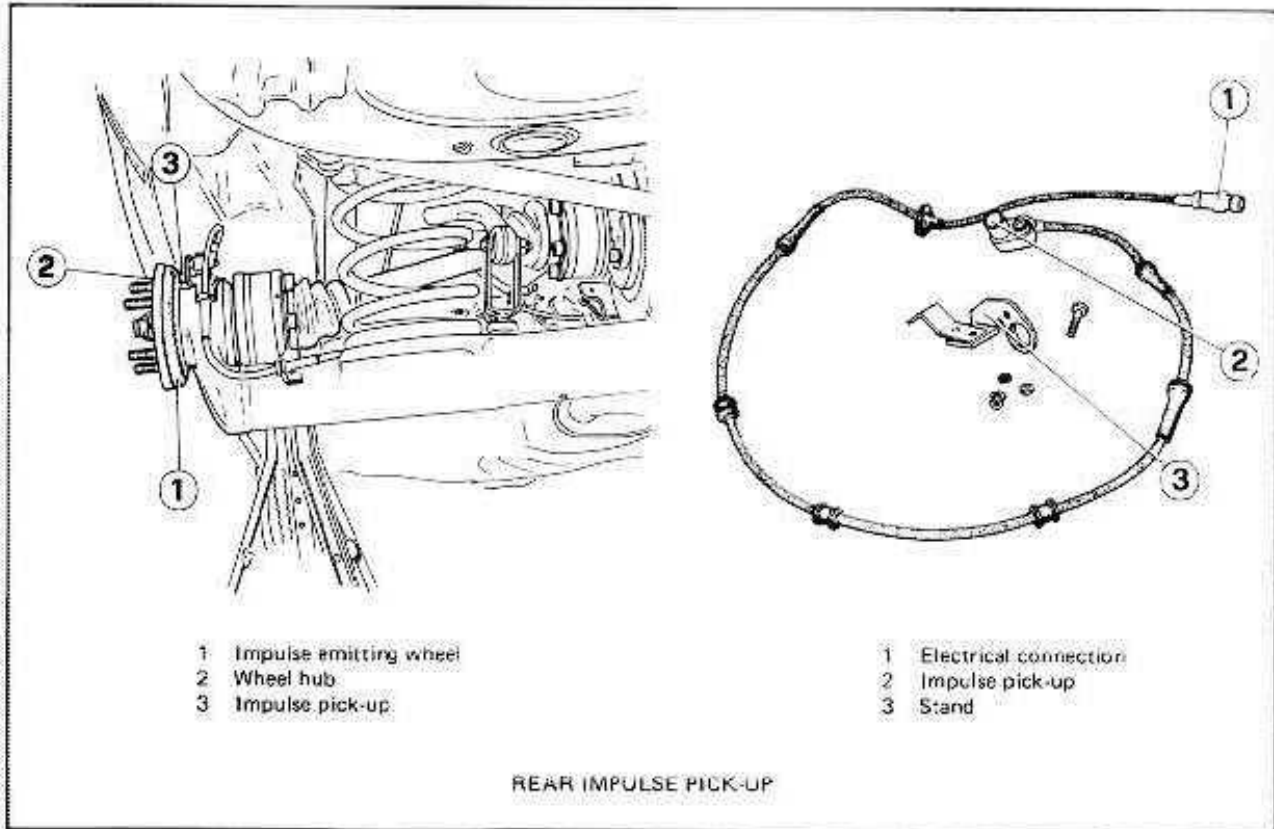

These are assembled one on each wheel and serve to supply the electronic unit with the speed datum of the wheel.

They comprise a permanent magnet cocooned by a copper coil (see figure 1). The operating principle is based on the variation of the magnetic field generated during the interception of the teeth on the impulse emitting wheel.

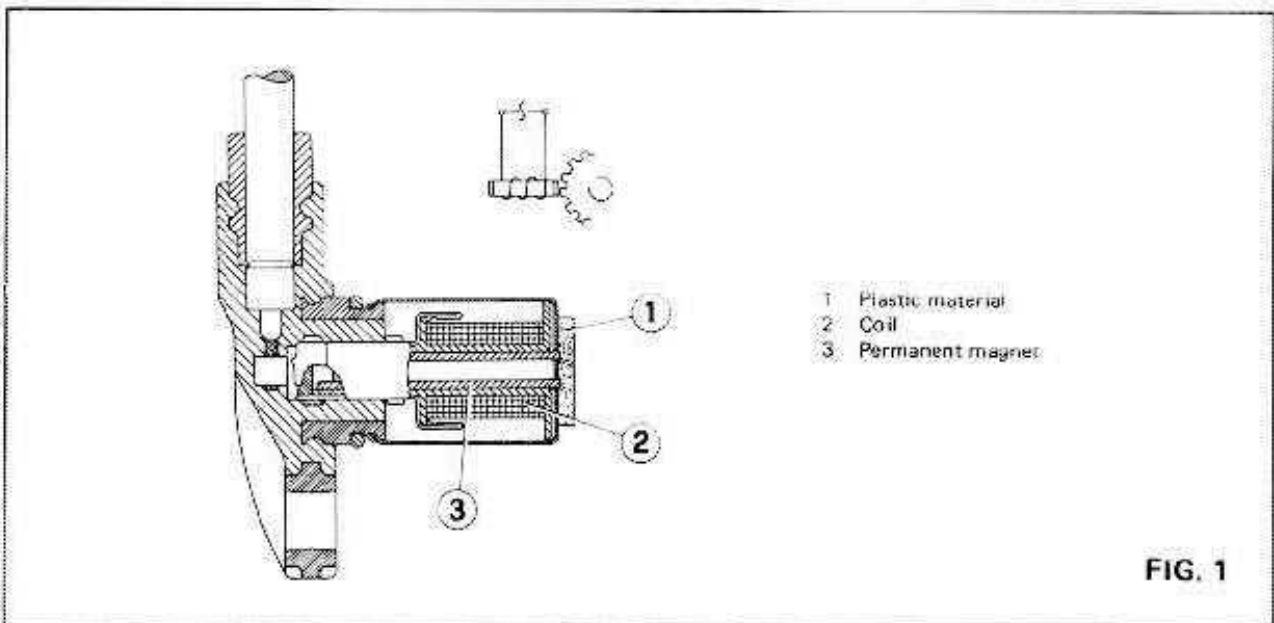

The signal generated is rather like a sinusoid recognisable by a frequency proportional to the speed of the wheel and by a amplitude which increases along with the speed and viceversa (see figure 2). Furthermore, the amplitude of the signal is also affected by the distance between the impulse pick-up and the impulse emitting wheel.

To this purpose, to avoid calibrating with a thickness gauge, the impulse pick-up head carries a plastic material with a calibrated thickness that is equal to the air gap required, making it possible to drive it home against the teeth of the impulse emitting wheel. Subsequently, after the wheel has rotated, the teeth of the impulse emitting wheel remove part of this plastic material thus eliminating the friction caused when the impulse pick-up is driven home.

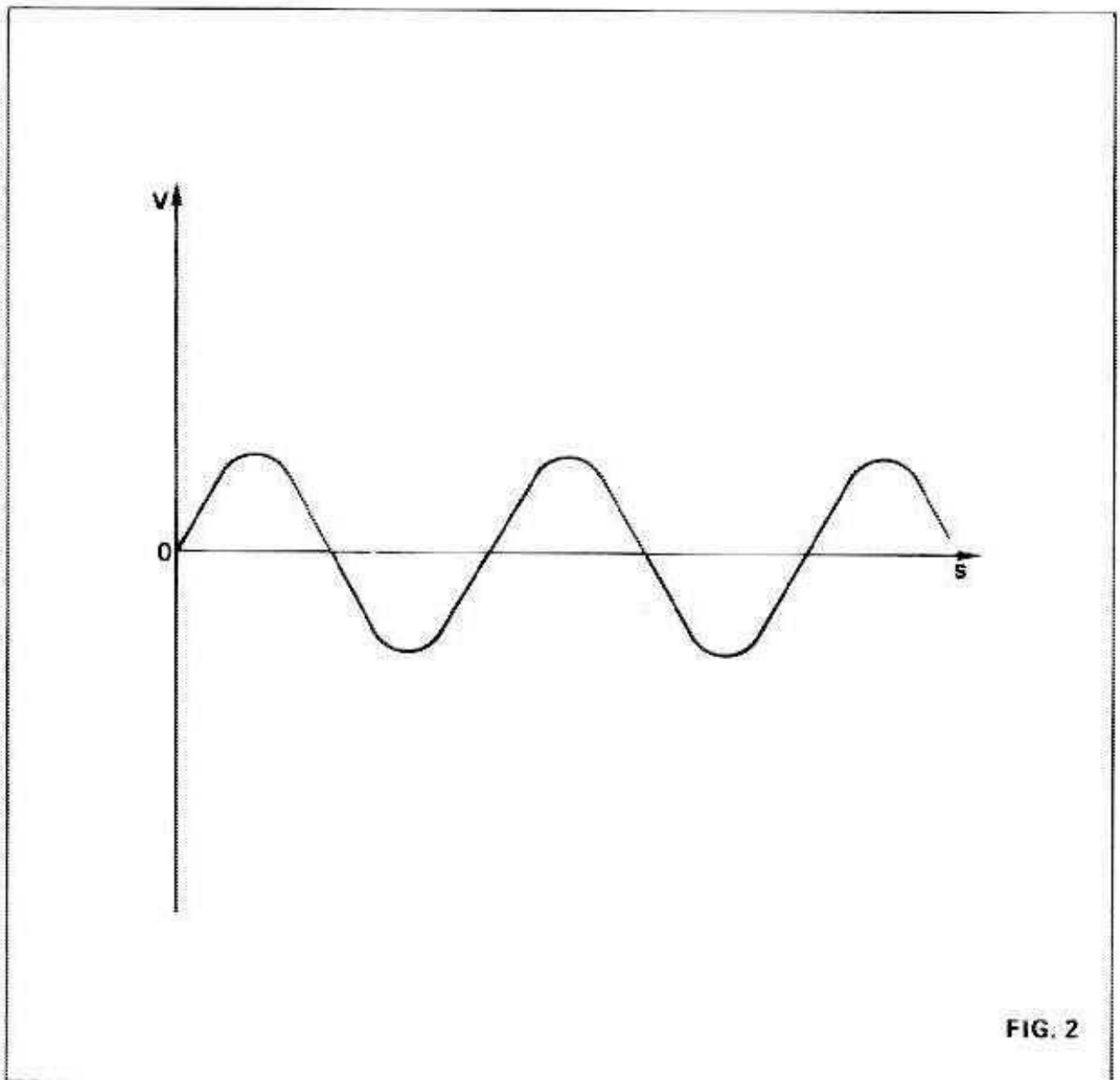

ELECTRONIC UNIT

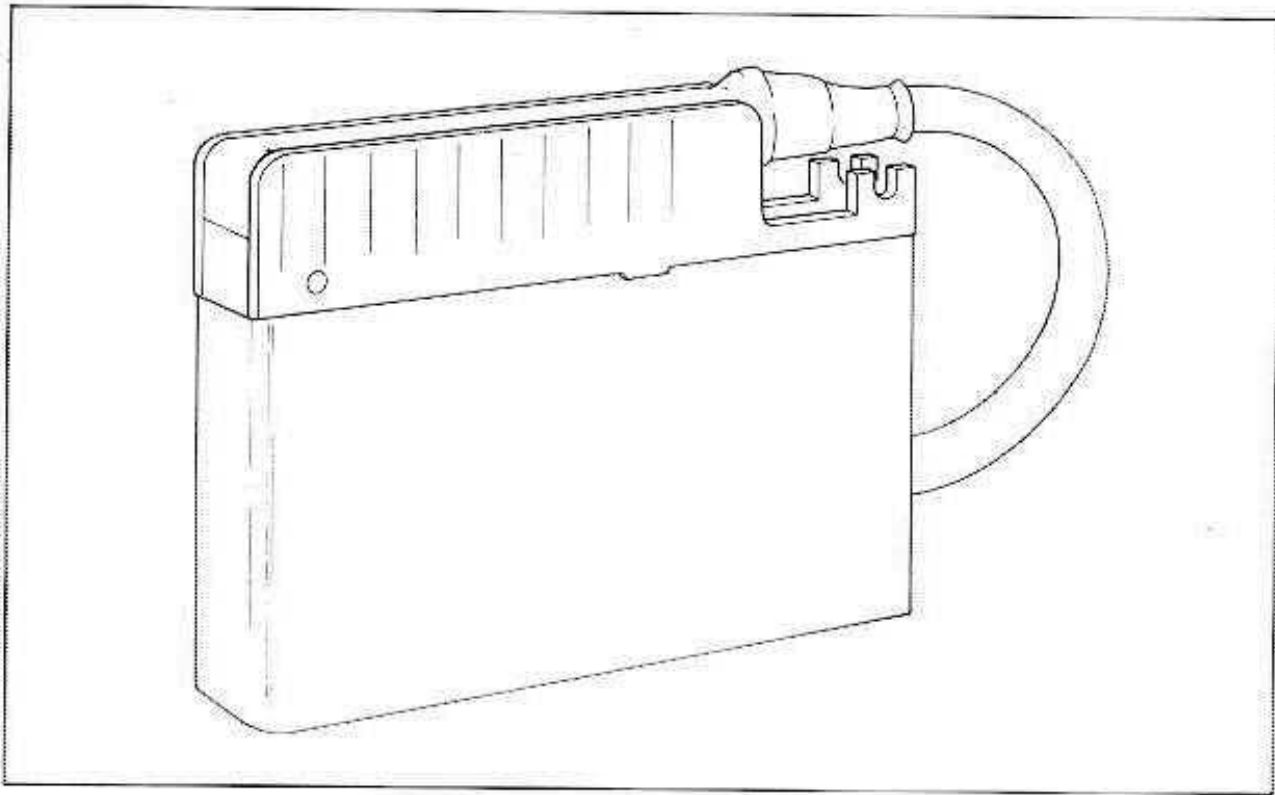

This is the heart of the ABS MARK II system. It receives signals from the four impulse pick-ups, one for each wheel and following appropriate processing handles the control of the electrovalves of the wheel or wheels tending to lock. Two identical electronic circuits (see figure 1) are contained within the unit, each handled by a micro-processor.

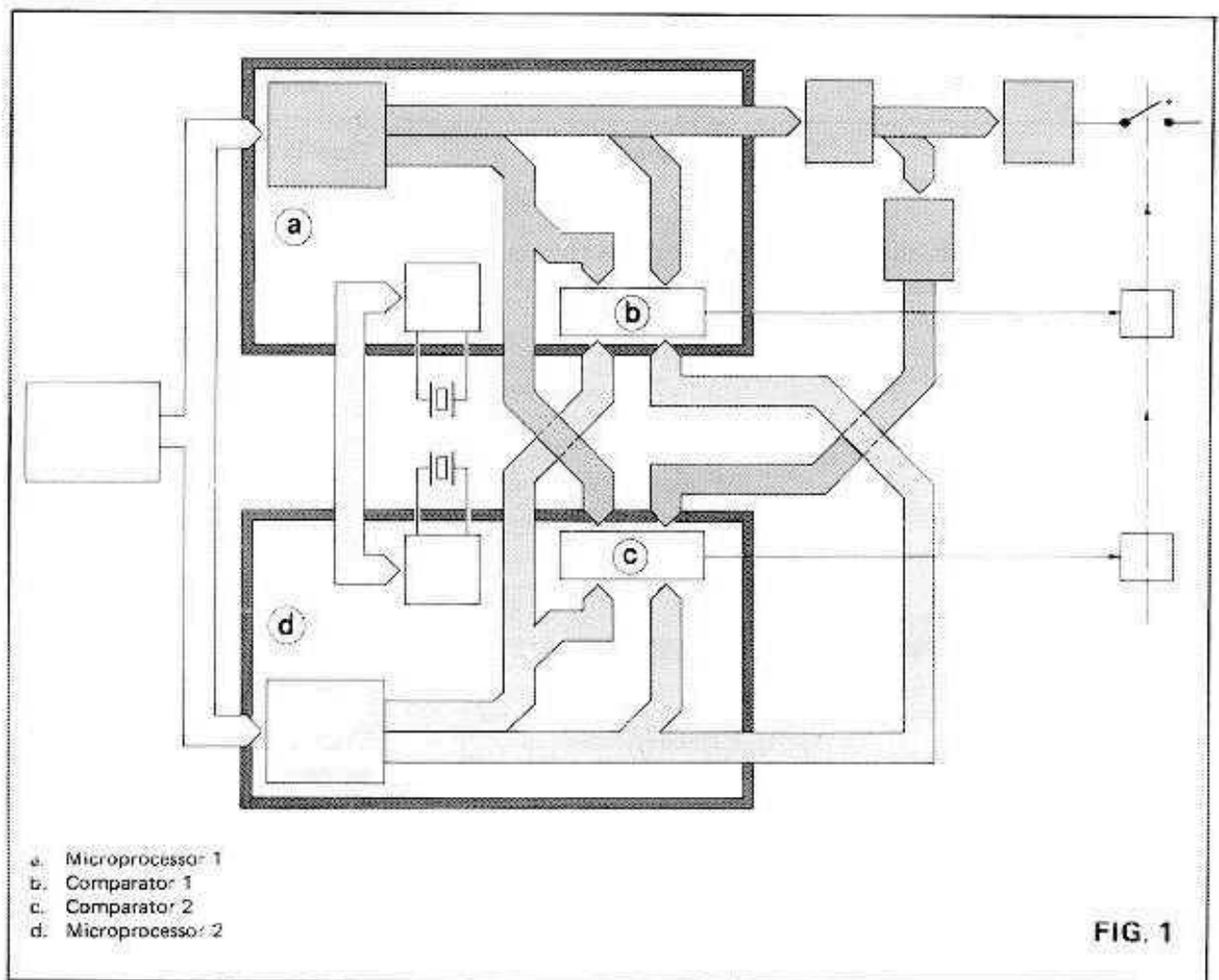

Each circuit processes the input data separately and determines which actuators to control. The data thus obtained are compared with one another and only when they have been proved to correspond is the command actually put into action.

Such a system, known as redundant logic (each circuit checks the other) allows considerable operational safety levels, such as those indeed requested of a braking system, to be attained.

Besides the above, the electronic circuits carry out continuous tests on the impulse pick-ups, actuators, accumulator pressure, brake oil level etc.

On the basis of all this the various conditions summarized in the following table may arise.

DEFECTS	UNIT CONDITION	EFFECT ON THE BRAKING SYSTEM
Unit components faulty	Unit disconnected	Traditional braking and A.S. warning light illuminated
Voltage trouble at impulse pick-ups or faulty connections	a) If the impulse pick-up is a front wheel one the front axis only is disconnected b) If the impulse pick-up is a rear wheel one the unit disconnects	Traditional braking on the front axis and A.S. warning light illuminated. The partial disconnection ceases along with the failure Traditional braking on all 4 wheels and the A.S. warning light illuminated. Disconnection persists until the failure is eliminated
Electrovalve failure or faulty connections	Unit disconnected	Traditional braking and A.S. warning light illuminated
Power loss	Unit disconnected	Traditional braking and A.S. warning light illuminated. No other indication due to loss of power
Scarse pressure in the accumulator or low brake fluid level	Unit disconnected	Traditional braking A.S. warning light illuminated, brake warning light on ALFA ROMEO CONTROL illuminated. According to the extent of the failure, servo assistance may lack
Considerable electromagnetic interference	Unit disconnected	Traditional braking and A.S. warning light illuminated

ABS DIAGNOSIS

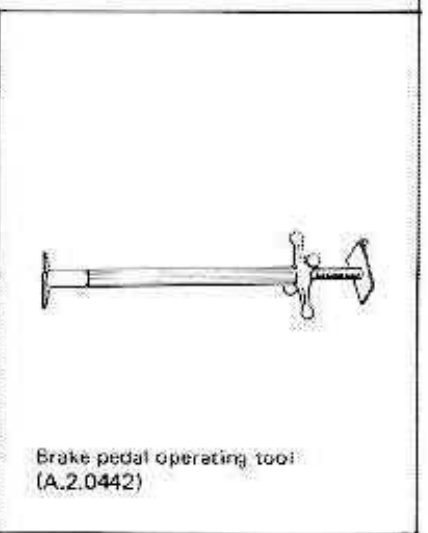
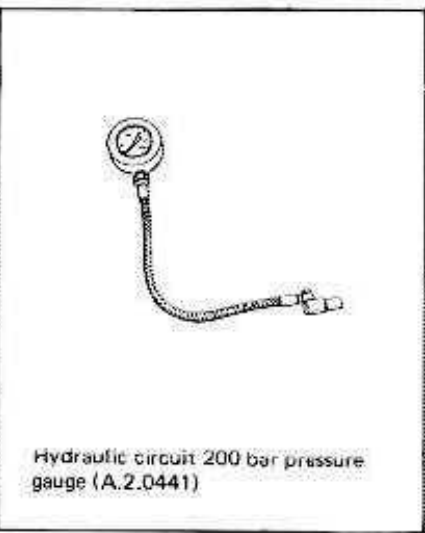
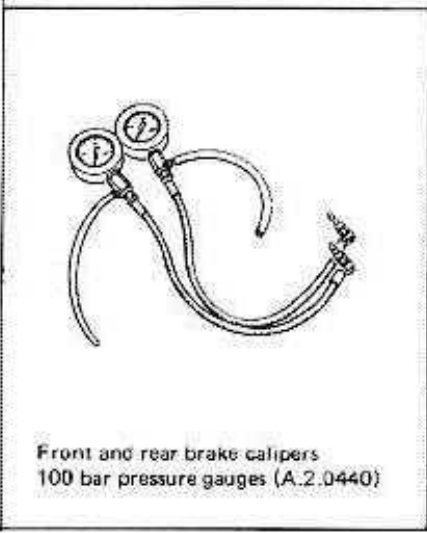
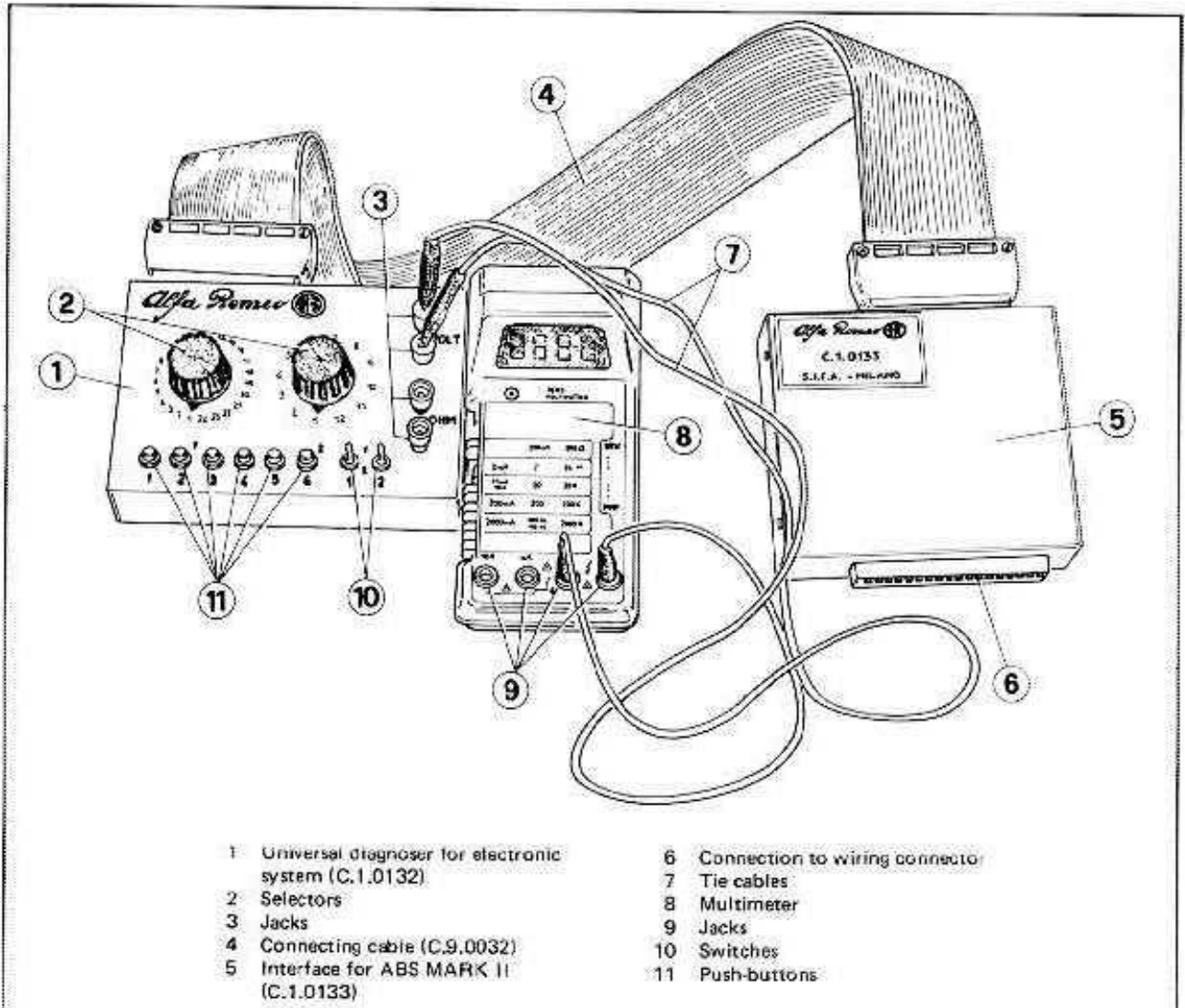

CAUTION

Prior to working on the hydraulic circuit, the brake fluid pressure should be completely discharged by pressing the brake pedal at least 20 times until it sticks, with the ignition key removed.

The circuit is at 180 bar.

PRELIMINARY OPERATIONS

- Remove the ignition key.
- Fully discharge the hydraulic circuit pressure.
- Connect the pressure gauge (A.2.0441) to the pump unit outlet.

TEST N° 1

- Ensure that the pressure in the hydraulic circuit is below 80 bar.
- Insert the ignition key and check the BRAKE OIL alarm on the A.R. CONTROL and the illumination of the A.S. warning light on the instrument panel.
- Check that the pressure in the hydraulic circuit starts to increase.
- Check that at approximately 145 bar the A.S. warning light extinguishes and the alarm on the A.R. CONTROL ceases.
- Check that the pressure does not exceed 180 bar.
- Check that the time elapsed on reaching 180 bar is no more than 60 seconds.

TEST N° 2

- With a pressurized hydraulic circuit (pump at a halt) and the key inserted, press the brake pedal several times.
- Check that when the pressure reaches 140 ± 4 bar the pump is activated thus restoring the pressure to 180 bar.

TEST N° 3

- Turn the key to the IGNITION position.
- Wait until maximum pressure (180 bar) is attained.
- Remove the key.
- Wait 3 minutes to allow pressure to stabilize perfectly.
- After 5 minutes check that the pressure leak is no more than 10 bar.

TEST N° 4

- Connect two 100 bar pressure gauges (A.2.0440) to the front calipers.
- Turn the key to the IGNITION position and wait until pressure is reached in the hydraulic circuit. Remove the key.
- Using a suitable tool (A.2.0442), press on the brake pedal until obtaining approximately 100 bar on the front caliper pressure gauges.
- Wait 3 minutes to allow the pressure to stabilize then check that the pressure leak does not exceed 5 bar in 5 minutes.

OHMMETRIC MEASUREMENT SET-UP

- Disconnect the connector from the ABS unit.
- Insert the diagnostic equipment interface (C.1.0133) in the cable connector.
- Ensure that the interface (C.1.0133) is connected to the switch assy (C.1.0132) by means of the cable supplied (C.9.0032).
- Set the rotating selectors to position 1.
- Set switches (1) and (2) to position 1.
- Verify that the pressure in the hydraulic circuit is 140 thru 180 bar.
- Remove the key.
- Insert the prods of an OHMMETER in the corresponding jacks of the diagnoser.
- Selectors (1) and (2) to position 1.

TEST N° 5

Impulse pick-ups test

- Selector (1) to position 1.
- OHMMETER 20 K Ω F.S.
- Read $2100 \pm 300 \Omega$ on the OHMMETER.
- Turn the selector (1) to position 2-3-4 and check that the value obtained is always between $2100 \pm 300 \Omega$.

CAUTION

The value read with the instrument is 1000 Ω greater than the real resistance of the impulse pick-ups.

TEST N° 6

A.S. warning light alarm SW test (tank and pressure switch)

- Selector (1) to position 5.
- OHMMETER 200 Ω F.S.
- Read 0 Ω on the OHMMETER.
- Remove the brake oil tank plug.
- Read infinite resistance on the OHMMETER.
- Replace the plug.
- Read 0 Ω again.
- Press the brake pedal several times.
- Read infinite resistance on the OHMMETER when the pressure goes below 105 bar.

TEST N° 7

Electrovalve test

- Set the OHMMETER to 200 Ω F.S.
 - Check the resistances indicated below for the various selector positions (1).
- | | |
|-------------|---------------------------------------|
| position 6 | 5 thru 8 Ω (front R.H. load) |
| position 7 | 3 thru 5 Ω (rear drain) |
| position 8 | 3 thru 5 Ω (front L.H. drain) |
| position 9 | 3 thru 5 Ω (front R.H. drain) |
| position 10 | 5 thru 8 Ω (rear load) |
| position 11 | 5 thru 8 Ω (front L.H. load) |
| position 12 | 2 thru 5 Ω (MAIN ELECTROVALVE) |

VOLTMETRIC MEASUREMENT SET-UP

- Remove the key.
- Selector (1) to position 1.
- Selector (2) to position 1.
- Switches (1) and (2) to position 1.
- Turn the key and wait until the maximum pressure is reached in the hydraulic circuit.
- Remove the key.
- Insert a VOLTMETER in the corresponding jacks of the diagnoser, observing correct polarity.

TEST N° 8

Control unit inhibit test during start-up phase

- Selector (2) to position 1.
- VOLTMETER 20V F.S.
- Turn the key to the IGNITION position.
- Read 12V on the VOLTMETER.
- Attempt to start and verify that the voltage goes down to 0V in this phase.

TEST N° 9

ABS control unit main supply test

- Selector (2) to position 2.
- VOLTMETER 20V F.S.
- Turn the key to the IGNITION position.
- Read 0V on the VOLTMETER.
- Put the switch (1) to position 2.
- Read 12V on the VOLTMETER.
- Turn the selector (2) to position 3.
- Carry out the same procedure as described for the selector in position 2.

TEST N° 10

Diode N29 diminished voltage test

- Selector (2) to position 4.
- Switch (1) to position 1.
- VOLTMETER 20V F.S.
- Turn the key to the IGNITION position.
- Read a voltage of 0.7 thru 0.8V on the VOLTMETER.
- Check, moreover, that the A.S. warning light on the panel is illuminated.
- Put the switch (1) to position 2.
- Read 12V on the VOLTMETER.
- Check, moreover that the A.S. warning light is extinguished.

TEST N° 11

Electrovalve ground efficiency test

- Selector (2) to position 5.
- Switch (1) to position 2.
- VOLTMETER 200 mV F.S.
- Turn the key to the IGNITION position.
- Read 0V on the VOLTMETER.
- Briefly press pushbuttons 1-2-3-4 individually, verifying that the voltage read on the VOLTMETER never exceeds 10 mV.

TEST N° 12

Impulse pick-up dynamic test

- VOLTMETER 2V F.S. in ALTERNATED CURRENT.
- Switch (1) to position 1.
- Raise the vehicle so that the wheels turn freely.
- Selector (2) to position 6.
Turn the R.H. rear wheel at approximately 1 rev per sec and read 0.15 thru 0.7V on the VOLTMETER.

- Selector (2) to position 7.
Turn the front L.H. wheel at approximately 1 rev per sec and read 0.15 thru 0.7V on the VOLT-METER.
- Selector (2) to position 8.
Turn the rear L.H. wheel at approximately 1 rev per sec and read 0.15 thru 0.7V on the VOLT-METER.
- Selector (2) in position 9.
Turn the front R.H. wheel at approximately 1 rev per sec and read 0.15 thru 0.7V on the VOLT-METER.

ELECTROVALVE DYNAMIC TEST SET-UP

- Switch off the key.
- **Ascertain that all previous tests proved positive, otherwise refrain from carrying out the following.**
- Selector (1) to position 1.
- Selector (2) to position 1.
- Switch (1) to position 2.
- Switch (2) to position 1.
- Raise the car enough to allow the wheels to turn freely.
- Insert the key and wait until the pressure in the hydraulic circuit reaches the maximum pressure of 180 bar.

TEST N° 13

Front L.H. load and drain electrovalve test

- Press the brake pedal quite hard.
- Check that the front L.H. wheel is locked.
- Press pushbutton 1 and check that the front L.H. wheel unlocks within 1-2 seconds.
- Release pushbutton 1.
- Verify a slight sinking of the brake pedal with a consequent wheel lock.
- Release the brake pedal.

WARNING

The pushbutton should never be pressed for more than 30 seconds; in the event of test repetition, allow at least the time for which the pushbutton was pressed to elapse between one test and the next in order to avoid the electrovalves overheating.

TEST N° 14

Front R.H. load and drain electrovalve test

Proceed as per the previous test by pressing pushbutton 2 and check the effect on the front R.H. wheel.

TEST N° 15

Rear load and drain electrovalve test

Proceed as per the previous test by pressing pushbutton 3 and check the effect on both rear wheels.

WARNING

Brake pedal sinking on release of the pushbutton will be less than in previous tests.

TEST N° 16

Main electrovalve test

- Press the pedal quite hard until test completion.
- Press pushbutton 1 several times until the brake pedal sinks completely.
- Press pushbutton 4.
- Check that the brake pedal returns to its initial position.
- Release pushbutton 4 and the brake pedal.

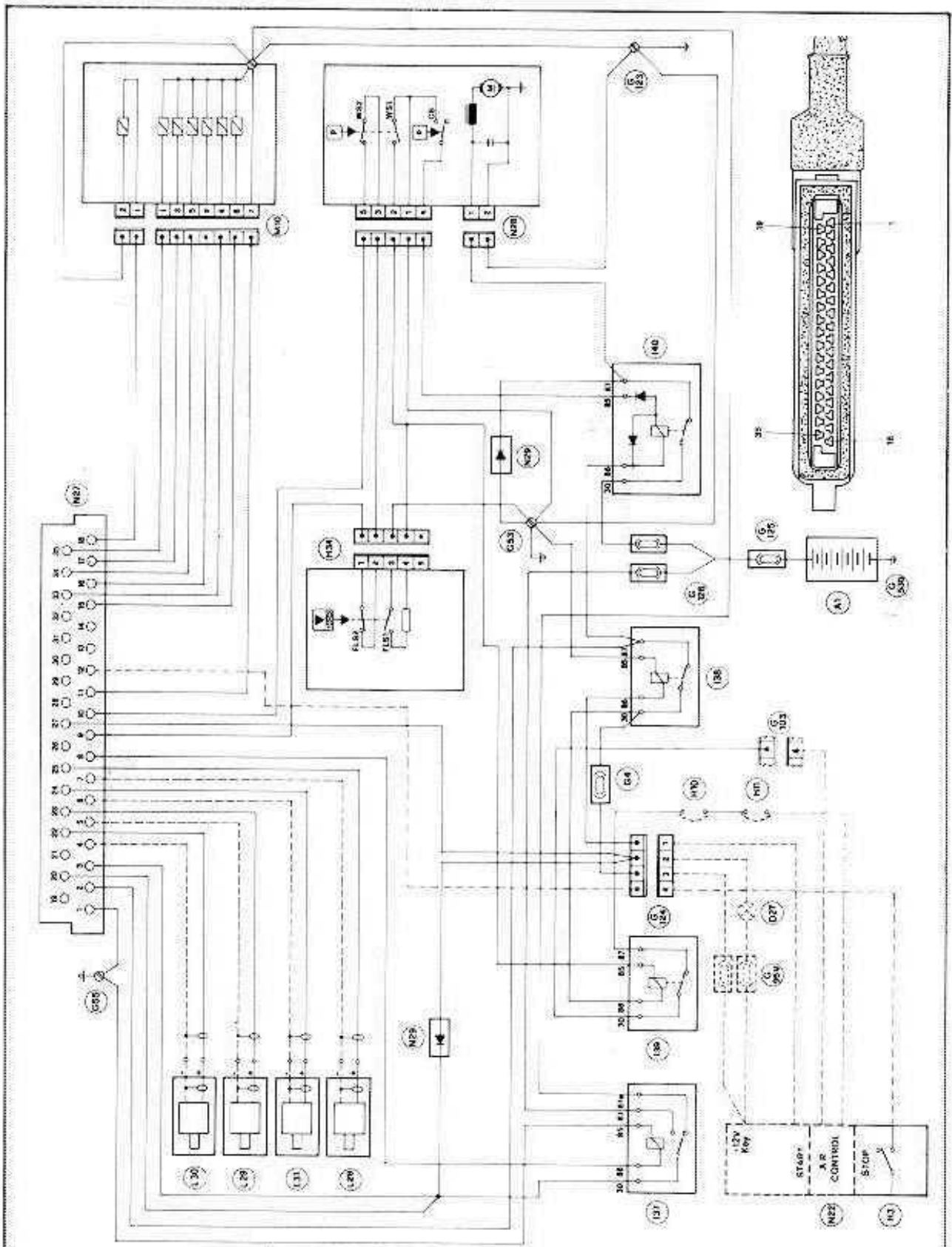

- A1 Battery
- D27 ABS system warning lamp
- G4 Fuse fusebox
- G53 Engine compartment ground
- G53b Engine compartment ground-left side
- G55 Hood ledge panel ground
- G95V Fuses
- G103 Connector for grounds and brake fluid tank
- G123 Pedal assembly ground
- G124 ABS system connector
- G125 ABS system free fusebox
- G126 ABS system relays safety fuses
- H3 Stop light switch
- H10 Front L.H. brake pad switch
- H11 Rear R.H. brake pad switch
- H34 ABS system brake fluid tank switch
- I37 ABS system unit relay
- I38 ABS system auxiliary relay
- I39 Brake fluid level warning lamp relay
- I40 ABS system brake fluid elec. trippump relay
- L28 Front R.H. inductive sensor
- L29 Front L.H. inductive sensor
- L30 Rear R.H. inductive sensor
- L31 Rear L.H. inductive sensor
- M10 Brake fluid adjusting valves
- N22 A.R. CONTROL unit
- N27 ABS system unit
- N20 Brake fluid electropump apparatus
- N29 Connection for free diode