

TRANSMISSION

GROUP 15

CONTENTS

DESCRIPTION	15-2	INSPECTION SPECIFICATIONS	15-10
PROPELLER SHAFT	15-3	General requirements	15-10
Removal	15-3	Checks and adjustments	15-10
Installation	15-4	Tightening torques	15-11
Front joint	15-4	TROUBLESHOOTING	15-11
Center bearing	15-6	TOOLS	15-11
Rear joint	15-9		

TRANSMISSION

DESCRIPTION

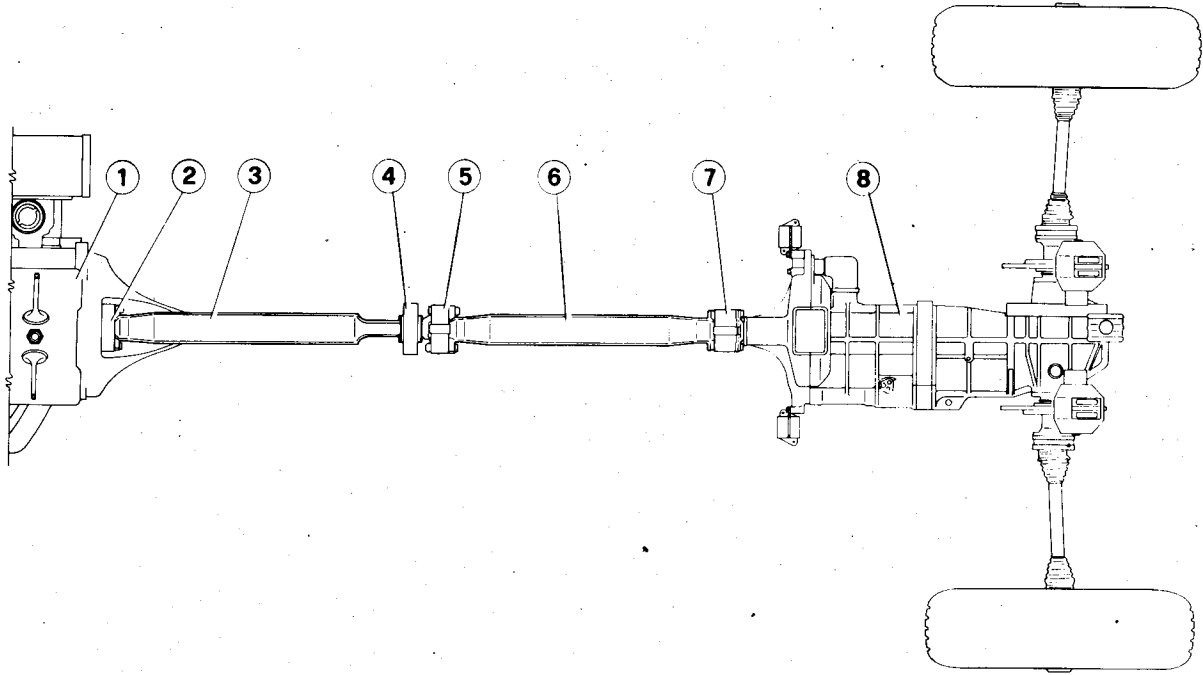

- 1 Engine
- 2 Front joint
- 3 Front shaft
- 4 Center bearing
- 5 Center joint
- 6 Rear shaft
- 7 Rear joint
- 8 Clutch - transmission - axle drive assembly

Drive line consists of shafting connecting engine to clutch - transmission - axle drive assembly.
This unique layout allows propeller shaft

to be positively connected to engine at all times.
Propeller shaft consists of two halves connected to one another and to anchor

points by means of flexible joints.
Propeller shaft is anchored to body through a center bearing assembly provided with a ball bearing.

PROPELLER SHAFT

REMOVAL

1. Raise car on a platform lift.
2. Remove exhaust pipe front and center section as specified in Group 04: Exhaust system - Removal.
3. Back off capscrews ② and remove center crossmember ①.

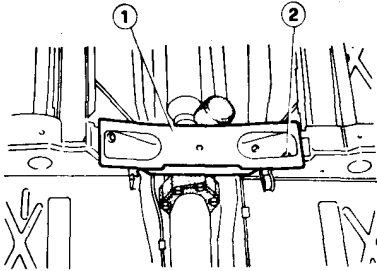

- 1 Center crossmember
- 2 Crossmember/body capscrew

4. Remove bellows ①, back off and remove bolt ② and disconnect rod ③.

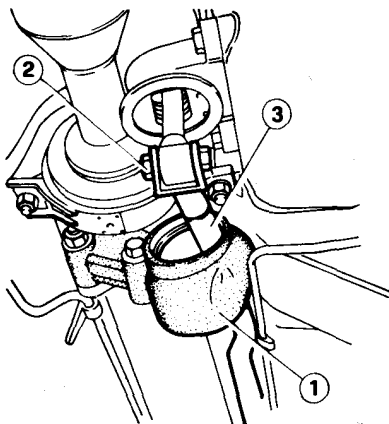

- 1 Bellow
- 2 Transmission remote control rod/lever bolt
- 3 Transmission remote control rod

5. Back off plate-bell housing securing bolts and remove plate.

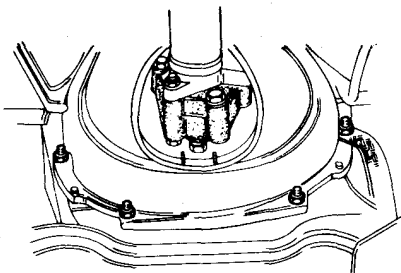

6. Disconnect bell housing from body.
 - a. For vehicles with high-torque propeller shaft (see: Group 00 - Complete Car - Use of Units in Car):
 - Back off capscrews ① and disconnect rear engine mount from body.

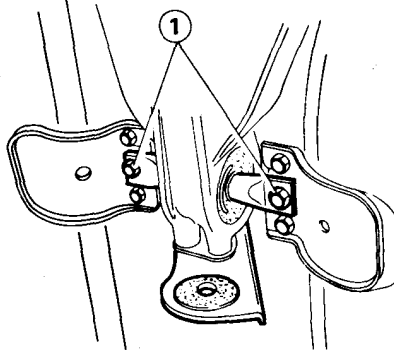

- 1 Rear engine mounting capscrews

- b. All other models:
 - Back off nuts ①, disconnect rear engine mount from body, retrieving spacers ②.

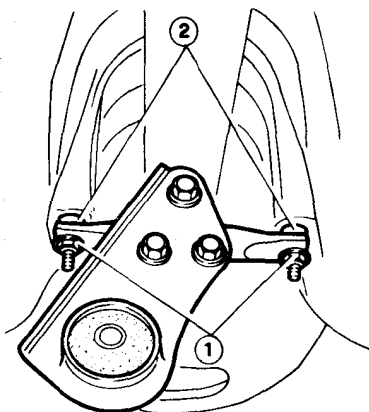

- 1 Rear engine mounting retaining nuts
- 2 Spacers

7. Clamp propeller shaft and back off bolts connecting shaft joints to flywheel and clutch fork; rotate shaft and back off the remaining bolts.

8. Back off six screws retaining axle front crossmember to body.

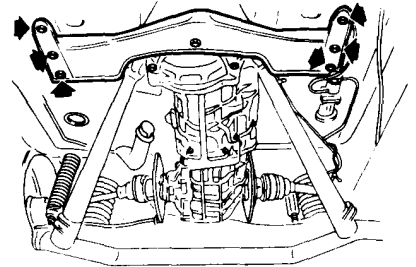

WARNING:

On **Alfetta** **Giulietta** and **GTV2.0** there is no need to disturb the crossmember.

9. Position a column lift provided with cradle A.2.0075 under De Dion axle.
10. Acting on De Dion axle, lower crossmember and transmission unit.

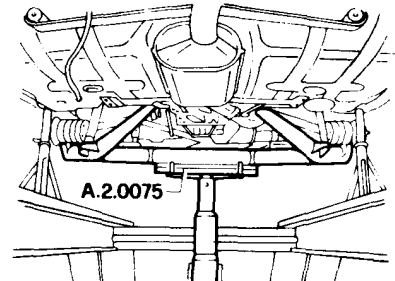

11. Back off nuts ① and disconnect support ② from body.

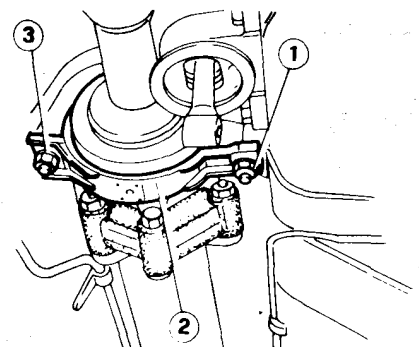

- 1 Center bearing to body retaining nut
- 2 Center bearing
- 3 Washer

TRANSMISSION

- 12. Take off shaft disconnecting from clutch shaft fork first and then from flywheel.

INSTALLATION

Install by reversing removal sequence and adhering to the instructions given below.

- Where not already carried out during overhaul, lubricate front bush and rear centering bush using the recommended grease (ISECO Molykote BR2) (quantity: see Inspection Specifications - Fluids and Lubricants).
If necessary, wet flywheel bush using the same type of grease.
- Tighten nuts retaining flexible joints to flywheel and clutch fork to the specified torque (see Inspection Specifications - Tightening Torques).

WARNING:

On assembly, use new self-locking nuts.

- Tighten transmission unit crossmember to body capscrews to the specified torque.

T: Tightening torque
Transmission unit crossmember to body capscrews
39 to 44 N·m
(4 to 4.5 kg·m)
(28.8 to 32.5 ft·lb)

- For 4 cylinder petrol and turbo diesel cars.

Check that distance A between the propeller shaft and the rear engine support is as specified.

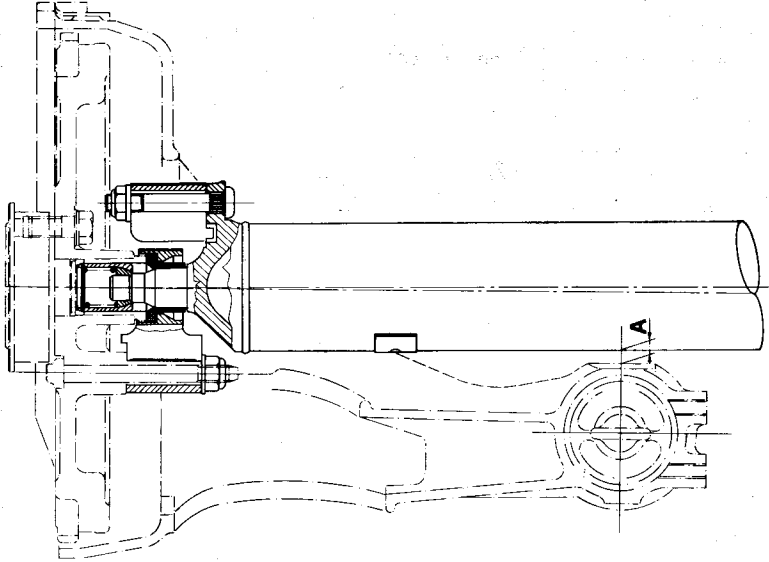

Distance A between the propeller shaft and rear engine support.

4 cylinder petrol run car:

A = 7 mm (0.28 in)

Turbo diesel car:

A = 24 mm (0.94 in)

If this distance differs from the specified one, vary the length of the spacers ① placed between the rear engine support ② and the body accordingly.

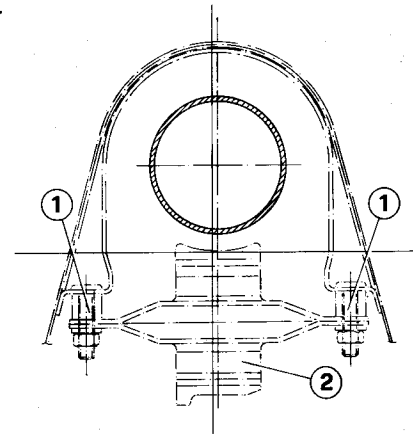

- 1 Spacer
- 2 Rear engine support

FRONT JOINT

- 1 Retaining ring
- 2 Washer
- 3 Spring
- 4 Ball cap
- 5 Bush
- 6 Rubber cap
- 7 Nut
- 8 Washer
- 9 Flexible member
- 10 Front shaft
- 11 Capscrew

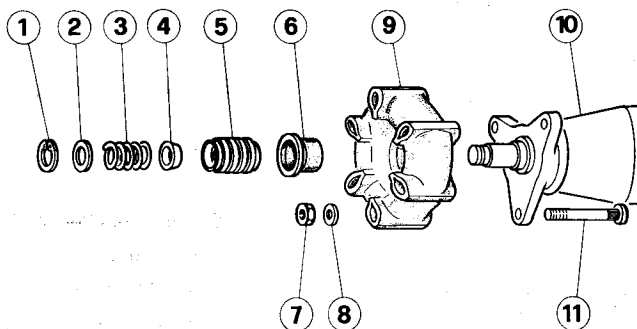

TRANSMISSION

DISASSEMBLY

1. Clamp front shaft in a vice and remove retaining ring ① from bush ④, take off washer ② and spring ③.

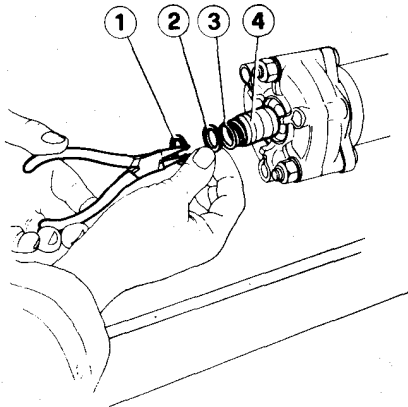

- 1 Retaining ring
- 2 Washer
- 3 Spring
- 4 Bush

2. Using tool **A.3.0361**, remove bush and ball joint from front shaft spigot.

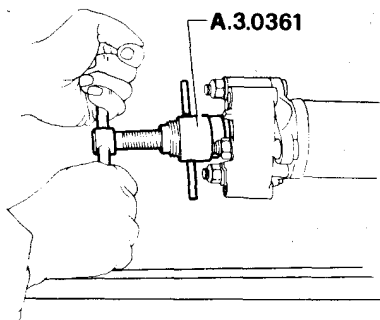

3. Install tool **A.2.0315** on flexible joint. Back off three nuts retaining joint ① to front shaft ②, retrieve associated washers, remove joint and rubber ring ③.

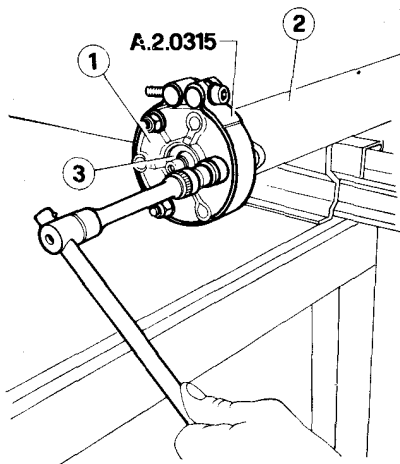

- 1 Flexible joint
- 2 Front shaft
- 3 Rubber ring

INSPECTION

Clean all parts

1. Check that bush and ball working surface is not worn; replace damaged parts as necessary.
2. Check flexible joint (replace if cracked or dented).

ASSEMBLY

1. Using tool **A.2.0315**, install flexible joint ① and position rubber ring ②.

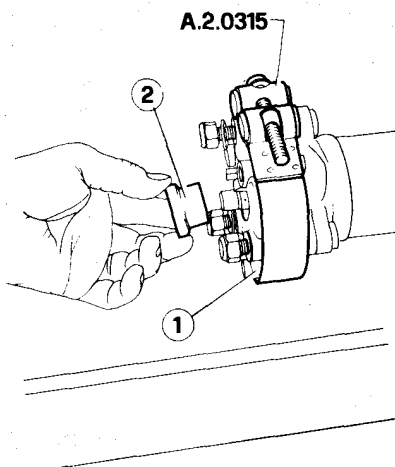

- 1 Flexible joint
- 2 Rubber ring

CAUTION:

If flexible joint has been replaced, tool **A.2.0315** is not required for assembly.

2. Tighten three flexible joint nuts with associated washers to the specified torques (see Inspection Specifications - Tightening Torques).

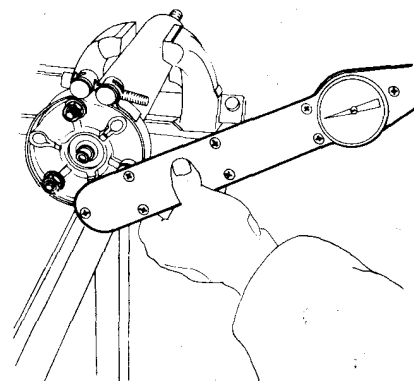

3. Lubricate bush using the recommended grease (ISECO Molykote BR2) (quantity: see Inspection Specifications - Fluids and Lubricants) and coat ball joint and bush working surfaces using recommended grease (ISECO Molykote G Rapid).
4. Insert ball cap in bush and position retaining ring on front shaft spigot using tool **A.3.0246**.

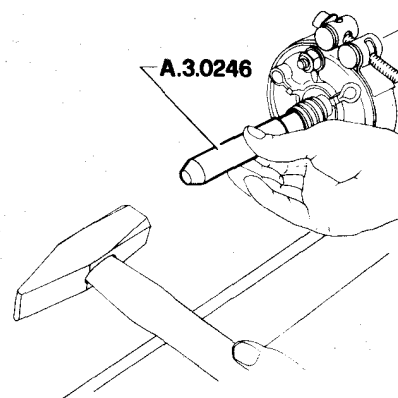

5. Insert spring and washer in bush and position retaining ring. Remove tool **A.2.0315**.

TRANSMISSION

CENTER BEARING

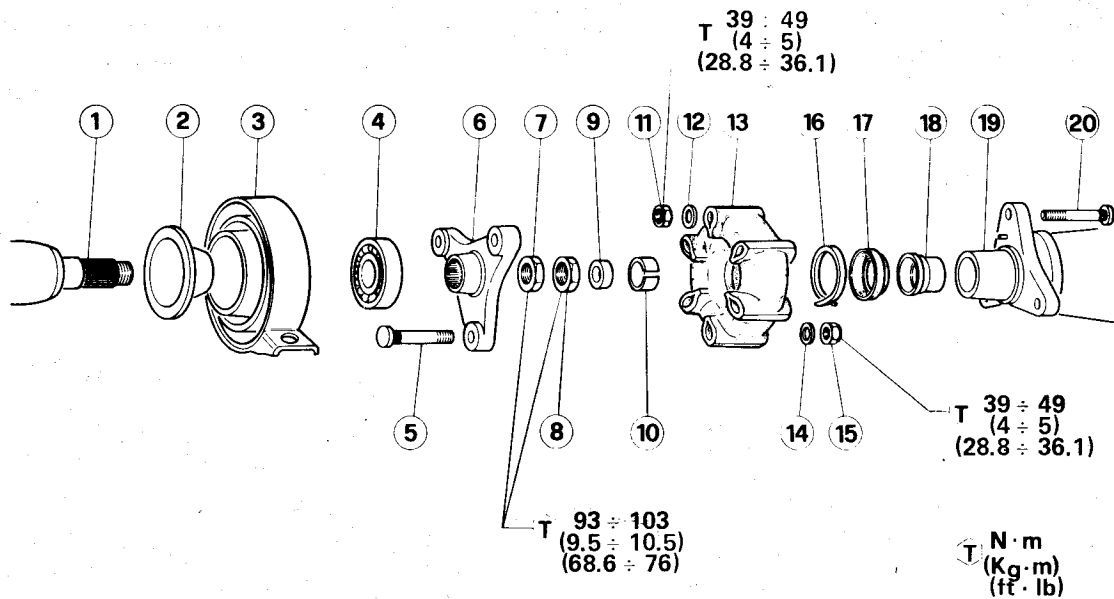

- 1 Front shaft
- 2 Cup
- 3 Center bearing support
- 4 Bearing
- 5 Capscrew
- 6 Fork
- 7 Nut

- 8 Locknut
- 9 Ball
- 10 Spherical seat
- 11 Nut
- 12 Washer
- 13 Flexible joint
- 14 Washer

- 15 Nut
- 16 Retaining ring
- 17 Rubber cap
- 18 Front bush
- 19 Rear shaft
- 20 Capscrew

DISASSEMBLY

1. Clamp front shaft ① in a vice, mark front and rear ② shaft position, install tool A.2.0315 on center flexible joint.

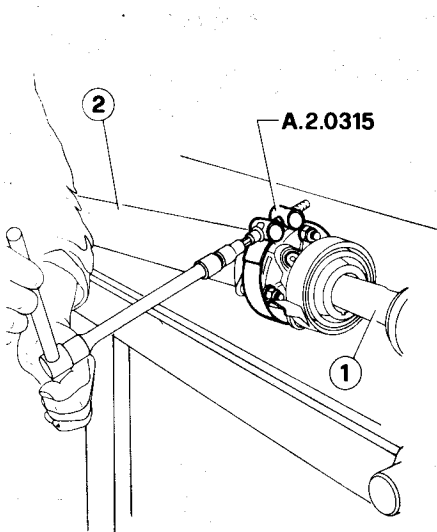

- 1 Front shaft
- 2 Rear shaft

2. Back off three nuts retaining front shaft to center bearing, remove associated washers and take off both shafts.

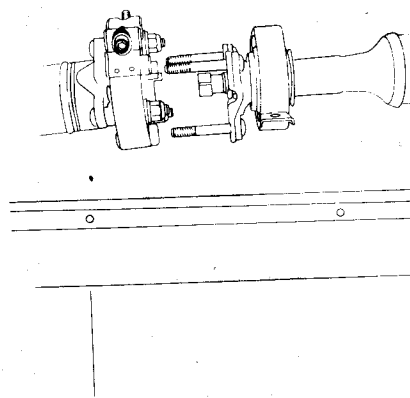

3. Mark front shaft fork and spigot to facilitate assembly.

4. Using a puller, take off spherical seat ① from front shaft spigot.

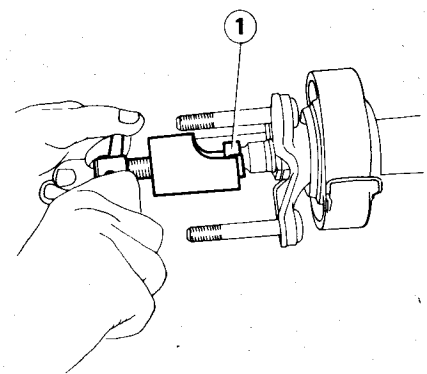

- 1 Spherical seat

5. Back off and remove locknut ① and nut ③ retaining fork ②.

TRANSMISSION

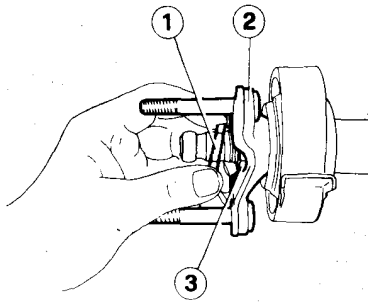

- 1 Locknut
- 2 Fork
- 3 Nut

6. Using a press with adapter plates of tool **A.2.0248** take off fork (1) from front shaft (2).

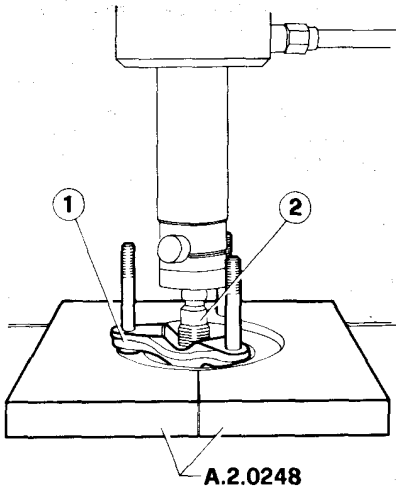

- 1 Fork
- 2 Front shaft spigot

CAUTION:

On disassembly do not damage fork as its replacement will affect shaft balancing.

7. Using a press with adapter plates of tool **A.2.0247**, take off center support (1) after marking front and rear sides, and retrieve associated cup.

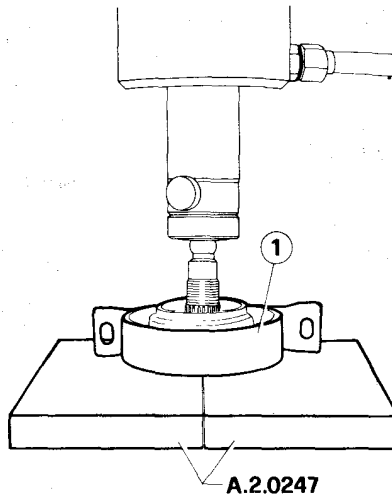

- 1 Center support

8. Using tool **A.3.0265/0002**, take off center support bearing at the press.

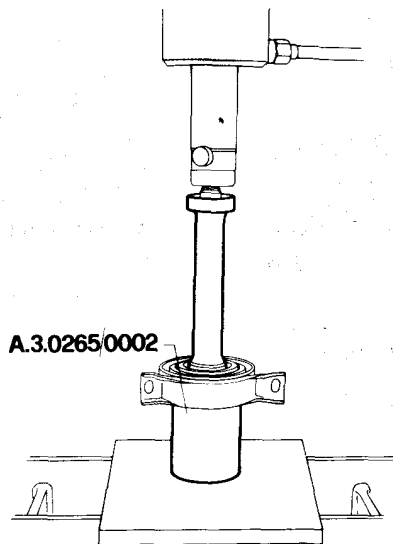

9. Take off ball (1) from front shaft spigot (2).

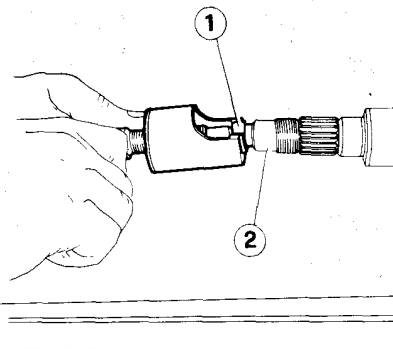

- 1 Ball
- 2 Front shaft spigot

10. Clamp rear shaft in a vice, mark center support position with respect to shaft, install tool **A.2.0315** on joint, back off three retaining nuts, remove associated washers and take off joint.

11. Remove rear shaft front bush rubber ring (1) after removing retaining ring.

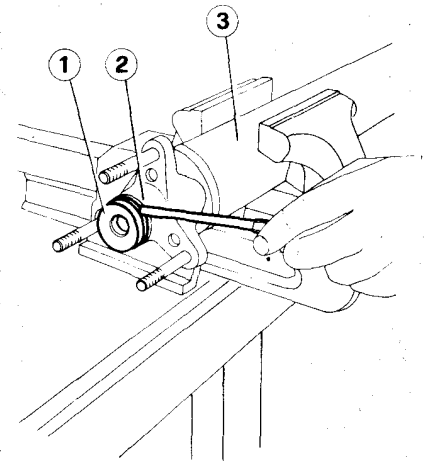

- 1 Rubber ring
- 2 Front bush
- 3 Rear shaft

INSPECTION

Clean all parts.

1. Check support bearing: replace if necessary.
2. Check that ball or spherical seat working surface is not worn or scored; replace damaged parts as necessary.
3. Check flexible joint; if cracked or dented, replace without hesitation.

ASSEMBLY

1. Lubricate bush and rubber ring using 5 cc of recommended grease (ISECO Molykote BR2).
2. Install rubber ring (2) in bush (1) and lock through associated retaining ring.

TRANSMISSION

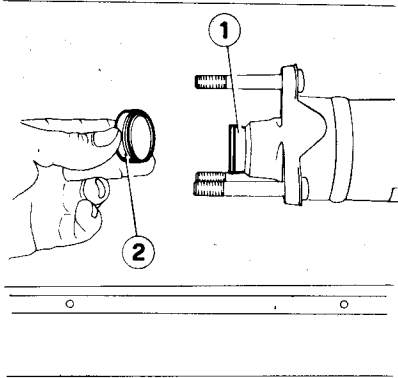

- 1 Bushing
- 2 Rubber cap

3. Using tool **A.2.0315**, install flexible joint ① on rear shaft, tighten three retaining nuts with associated washers to the specified torque.

T : Tightening torque
Center flexible joint/rear shaft nuts

39 to 49 N · m
(4 to 5 kg · m)
(28.8 ÷ 36.1 ft · lb)

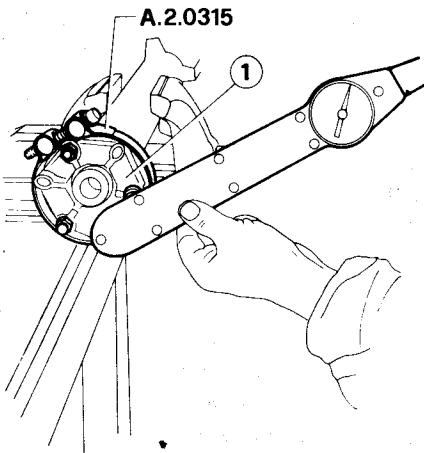

- 1 Flexible joint

CAUTION:

- a. Do not remove tool **A.2.0315** as it will be needed to assemble propeller shaft.
- b. If flexible joint has been replaced, tool **A.2.0315** is not required for assembly.

- 4. With a press, insert bearing fully home in center support.
- 5. Install cup on front shaft and install center support according to reference marks previously applied.
- 6. Assemble fork aligning reference marks previously applied.

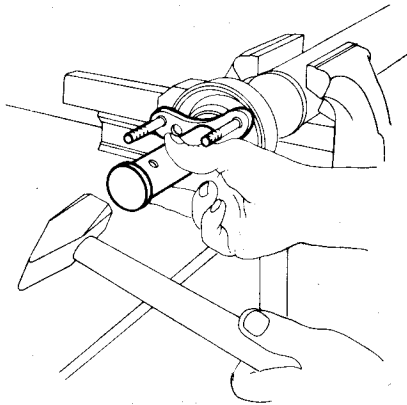

7. Tighten fork and center support nut and locknut to specified torque.

T : Tightening torque
Fork and center support retaining nuts

93 to 103 N · m
(9.5 to 10.5 kg · m)
(68.6 to 76 ft · lb)

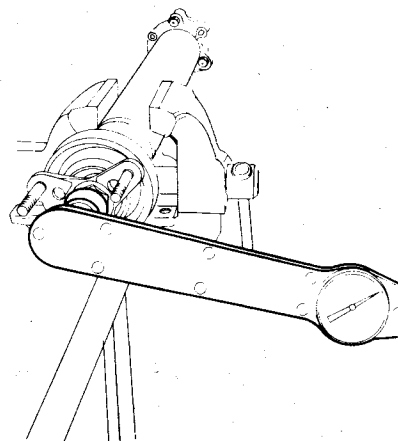

8. Using tool **A.3.0244**, install ball ① on front shaft rear spigot ②.

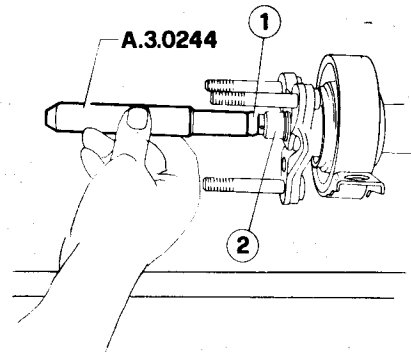

- 1 Ball
- 2 Front shaft spigot

- 9. Coat ball and spherical seat working surface using recommended grease (ISECO Molykote G. Rapid).
- 10. Using a plastic mallet, install spherical seat ①.

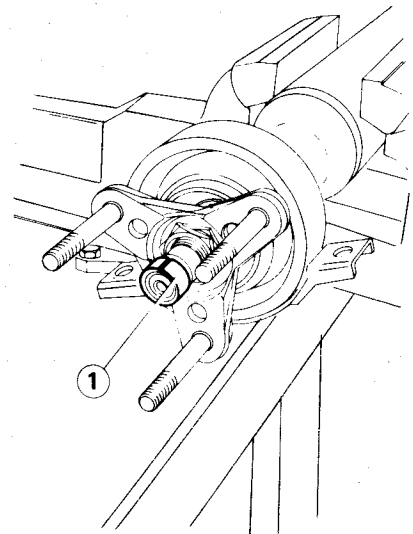

- 1 Spherical seat

11. Aligning reference marks applied on disassembly, assemble propeller shaft connecting front shaft to rear shaft. Tighten three nuts with associated washers retaining the two shafts to the specified torque.

T : Tightening torque
Center flexible joint/front shaft retaining nuts

39 to 49 N · m
(4 to 5 kg · m)
(28.8 to 36.1 ft · lb)

TRANSMISSION

REAR JOINT

- 1 Capscrew
- 2 Rear shaft
- 3 Ball
- 4 Spherical seat
- 5 Retaining ring
- 6 Rubber cap
- 7 Flexible joint
- 8 Washer
- 9 Nut
- 10 Seal

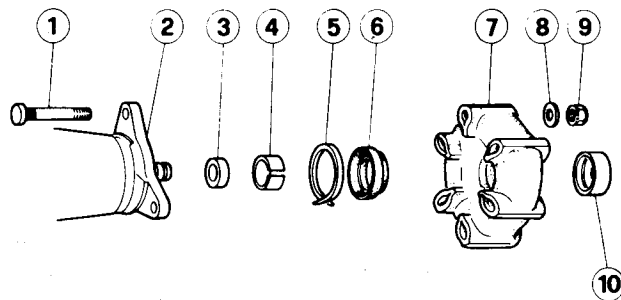

DISASSEMBLY

1. Clamp rear shaft in a vice and take off rear seal.
2. Install tool **A.2.0315** on flexible joint, back off three retaining nuts, retrieve associated washers, take off flexible joint and rubber cap, after removing retaining ring.
3. Take off spherical seat and remove ball (1) from spigot (2) of rear shaft (3).

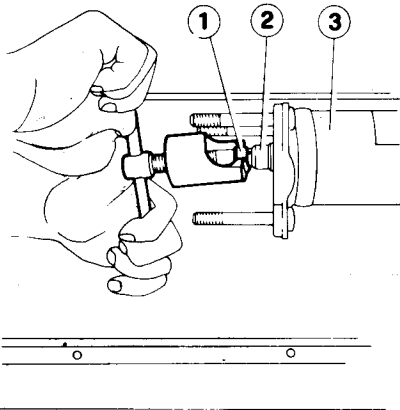

- 1 Ball
- 2 Spigot
- 3 Rear shaft

INSPECTION

Clean all parts.

1. Check that ball or spherical seat working surface is not worn or scored; replace damaged parts as necessary.
2. Check flexible joint; if cracked or dented, replace without hesitation.

ASSEMBLY

1. Using tool **A.3.0244**, install ball (1) on rear shaft (3) spigot (2).

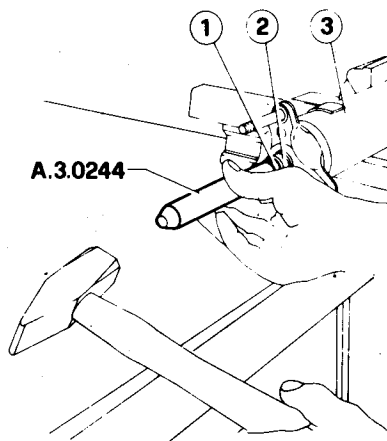

- 1 Ball joint
- 2 Spigot
- 3 Rear shaft

2. Lubricate rear centralizing bush in position on flexible joint using the recommended grease (ISECO Molykote BR2) (quantity: see Inspection Specifications - Fluids and Lubricants).
3. Install seal on bush and secure through retaining ring.
4. Using tool **A.2.0315**, install flexible joint, tighten 3 retaining nuts with associated washers to the specified torque (see Inspection Specifications - Tightening Torques).

WARNING:

If flexible joint has been replaced, on assembly tool **A.2.0315** is not required.

5. Install seal, positioning lip on rear bush.

INSPECTION SPECIFICATIONS

GENERAL REQUIREMENTS

FLUIDS AND LUBRICANTS

Description	Type	Recommended product	Quantity	
			Cars with transmission for high torques	All other cars
Flywheel bush Propeller shaft front bush Center bush and rubber ring Rear centralizing bush on flexible joint	GREASE	ISECO: Molykote BR2 Part. No. 3671-69841	Coat with 5 cc (0.3 cu.in) 5 cc (0.3 cu.in) 5 cc (0.3 cu.in)	Coat with 10 cc (0.6 cu.in) 5 cc (0.3 cu.in) Fill up
Front clearance take up ball and spherical bush working surface Center ball and spherical seat working surface Rear ball and spherical seat working surface	GREASE	ISECO: Molykote G Rapid Part. No. 3671-69842	Coat Coat Coat	Coat Coat Coat

CHECKS AND ADJUSTMENTS

For 4 cylinder petrol and turbodiesel cars

Distance A between the propeller shaft and rear engine support

4 cylinder petrol run car
A = 7 mm (0.28 in)

4 cylinder turbodiesel car
A = 24 mm (0.94 in)

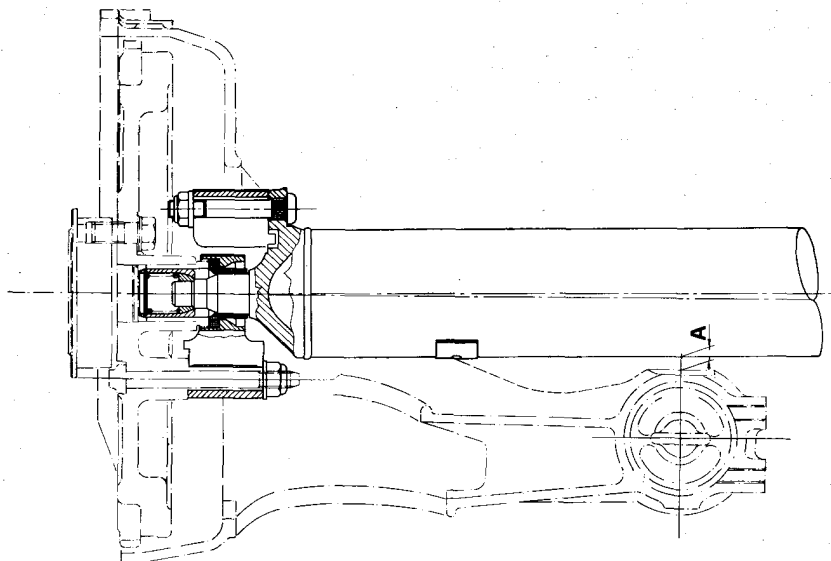

TRANSMISSION

TIGHTENING TORQUES

[N·m (kg·m: (ft·lb))]

Description	Cars with transmission for high torques	All other cars
Nuts, front/rear flexible joint	55 to 57 (5.6 to 5.8) (40.6 to 42)	39 to 49 (4 to 5) (28.8 to 36.1)
Nuts, center flexible joint to propeller shaft yokes	39 to 49 (4 to 5) (28.8 to 36.1)	39 to 49 (4 to 5) (28.8 to 36.1)
Nuts, fork and center bearing	93 to 103 (9.5 to 10.5) (68.6 to 76)	93 to 103 (9.5 to 10.5) (68.6 to 76)
Capscrews, transmission crossmember to body	39 to 44 (4 to 4.5) (28.8 to 36.1)	39 to 44 (4 to 4.5) (28.8 to 36.1)



TROUBLESHOOTING

Fault	Cause	Remedy
Noise and chatter under any running condition	<ul style="list-style-type: none"> • Worn flexible joints • Loose flexible joint nuts • Worn center bearing • Loose center bearing support cap-screws 	Replace worn joints Tighten nuts Replace bearing Tighten screws
Chatter during sharp torque changes	<ul style="list-style-type: none"> • Worn flexible joints • Loose flexible joints nuts 	Replace worn joints Tighten joint nuts

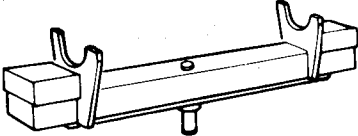
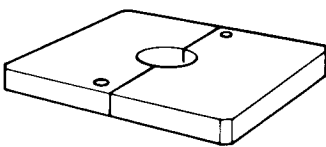
TOOLS

Part No.	Description	Page
A.2.0075	Support, car lift 	15-4
A.2.0247	Adapter plates, front shaft center support 	15-7

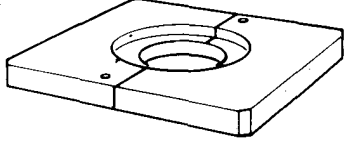
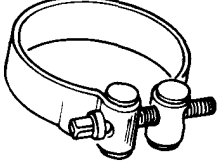
TRANSMISSION

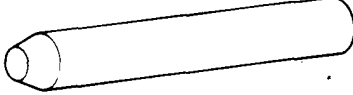
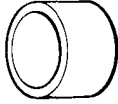
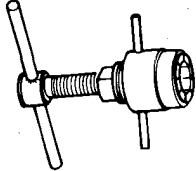
Part No.	Description	Page
A.2.0248	Adapter plates, center joint yoke 	15-7
A.2.0315	Remover/replacer, flexible joint 	15-5 15-6 15-8 15-9
A.3.0244	Installer, ball front/rear shaft 	15-8 15-9
A.3.0246	Installer, ball with bush, front shaft 	15-5
A.3.0265/0002	Remover, center bearing, front shaft 	15-7
A.3.0361	Remover, front/rear ball, propeller shaft 	15-5