

GROUP 05

CONTENTS

BATTERY	05-2	Removal	05-36
ELECTRICAL SYSTEM	05-4	Inspection	05-40
Inspection specifications	05-10	Assembly	05-42
Components (Alfa 75 - Alfa 90 -		Bench test	05-42
Alfetta - GTV 6 2.5)	05-11	Inspection specifications	05-43
Components (Giulietta)	05-12	Troubleshooting	05-45
Components (GTV 2.0)	05-13	BREAKERLESS IGNITION	05-46
Components (Alfa 75 1.8 turbo)	05-13	Description	05-46
STARTING	05-14	On-vehicle tests and inspection	05-47
Disassembly	05-19	Disassembly	05-53
Inspection	05-25	Inspection	05-56
Assembly	05-27	Assembly	05-56
Bench test	05-27	Bench test	05-56
Inspection specifications	05-28	On-vehicle distributor installation	05-57
Troubleshooting	05-31	Inspection specifications	05-59
CHARGING	05-33	Troubleshooting	05-64

6 cylinders **Alfa 90 2.0 6V iniezione**

MASTER RESET SENSOR	05-65	Electrical tests	05-69
Description	05-65	Replacement	05-69
Electrical tests	05-65	SPECIFICATION	05-70
Distributor removal	05-65	Master reset	05-70
Distributor installation	05-68	Distributor	05-70
IGNITION COIL	05-69	Ignition coil	05-71
DESCRIPTION	05-69		

BATTERY

CAUTION:

- a. Do not touch positive and negative battery poles simultaneously with bare hands.
- b. When starting engine with jumper leads through auxiliary battery, source voltage should not exceed 12 V.

INSPECTION

- a. Check battery container for cracks.
- b. Ensure that electrolyte level is 4 to 5 mm (0.15 to 0.20 in) above top of plates.
- c. Check that battery top is clean and that contacts are free from oxidation.
- d. Check terminal clamps for tightness, to ensure efficient contact.

CLEANING

- a. Clean battery top, posts and clamp using a solution of water and sodium bicarbonate.
- b. Prior to installing clamps, coat with the specified type of grease (REINACH: E10 Tac).

NOTE:

Do not allow cleaning solution to mix with electrolyte, as the two react chemically. Remember that electrolyte is an acid and constitutes a hazard for eyes, hands and clothes.

DENSITY CHECK

- a. Check electrolyte level.
- b. Use a hydrometer to check density in each element.

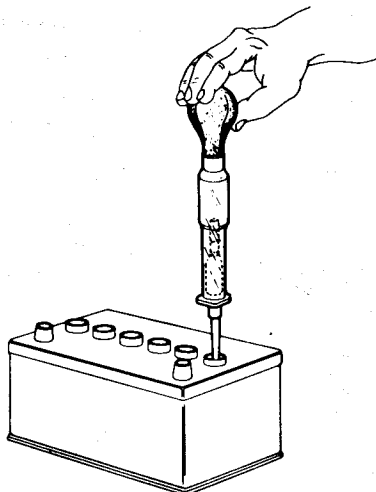

- c. Measure electrolyte temperature «t» by dipping a thermometer bulb in the fluid.
- d. Check density at 25°C (77°F) using the following formula:

$$d_{25} = d_t + 0.0007 (t - 25) \text{ (kg/dm}^3\text{)}$$

where d_t is density at temperature $t^\circ\text{C}$

Examples:

- 1. Reading at 15°C (59°F):
1.290 kg/dm³

Density at 25°C (77°F) will be:

$$d_{25} = 1.290 + 0.0007 (15 - 25) = 1.283 \text{ kg/dm}^3$$

- 2. Reading at 35°C (95°F):
1.275 kg/dm³

Density at 25°C (77°F) will be:

$$d_{25} = 1.275 + 0.0007 (35 - 25) = 1.282 \text{ kg/dm}^3$$

- e. Compare calculated density at 25°C (77°F) to reading required for an efficient battery.

Electrolyte density of efficient battery
 $d = 1.28 \pm 0.01 \text{ kg/dm}^3$

- f. Recharge battery as necessary.

Batteries left in storage or fitted to vehicles remaining inoperative for long periods are subject to slow discharging, and should be recharged immediately before use.

RECHARGING

NOTE:

- a. Prior to recharging batteries disconnect negative terminal.
- b. Make sure that electrolyte temperature does not exceed 45°C (139°F) during recharging.

CAUTION:

- a. Do not use open flames in the neighbourhood of battery when recharging.
- b. When using a battery charger, connect leads to battery first, and then activate charger.

ELEMENT TESTING

To be carried out after hydrometer test to ensure that density is correct.

Check discharge voltage across terminals of each element proceeding as follows:

- a. Remove filler caps.
- b. Dip tester prongs in two adjacent holes (positive and negative) as shown and check that needle moves over the green sector, indicating a good state of charge.
- c. Repeat the above operation on the two remaining pairs of filler holes.

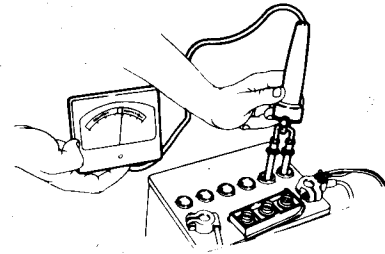

- d. If needle dwells over red sector (insufficient charge) and the three readings are equal, the battery should be recharged.
- e. If needle remains over red sector (low charge) and the three readings are considerably different from one another, the battery should be replaced.

ELECTRONIC TEST (MOTOROLA TESTER)

Connect positive tester clip to battery positive terminal post and negative clip to negative post.

Turn switch (3) to 12 V, temperature compensator (2) to estimated battery temperature and selector (4) to current rating depending on type of battery under test.

Voltage test

- a. Turn selector (1) to «VOLT».
- b. Check reading on voltage scale. The voltage is correct if the reading is higher than 12.4 V.

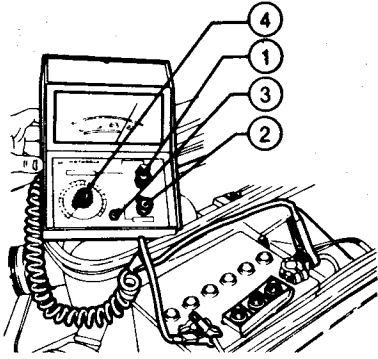

1. Selector
2. Temp. compensator
3. Battery voltage switch
4. Calibration switch

c. If battery voltage is below 12.4 V, recharge battery and repeat voltage test. If the trouble persists, element short circuit (S/C) may be the cause. Replace battery without hesitation.

Battery condition check

- a. Turn selector to «Cond. Batt.».
- b. Check on RED-GREEN scale that needle lies over GREEN sector.
- c. If needle lies over RED sector replace battery.

Output test

- a. Turn selector to «kW» on tester.
- b. Check that needle reads 2 to 4 kW.
- c. If reading is not as specified replace battery.

Charging test

- a. Turn selector to «VOLT».
- b. Start engine and run in no-load condition until tester needle stabilizes.
- c. Needle should read 13.6 to 15 V.
- d. If reading is lower or higher check for alternator anomalies, paying particular attention to voltage regulator (see: Recharging - Inspection).

Also check alternator belt tension. (For servicing and adjustment data refer to «Inspection Specifications» paragraph in individual Group of this manual. For Alfa 90 vehicles, see also Group 00 of publication: PA360300000000).

Starting test

- a. Move tester selector to «VOLT».
- b. Neutralize ignition system by disconnecting coil H.T. lead.
- c. Start engine and check on «VOLT» scale that needle does not read below 9 V.
- d. If reading is lower than specified check starting system (see: Starting).

ENGINE IGNITION, STARTER, CHARGING

ENGINE IGNITION Alfa 75 1.6 1.8 2.0

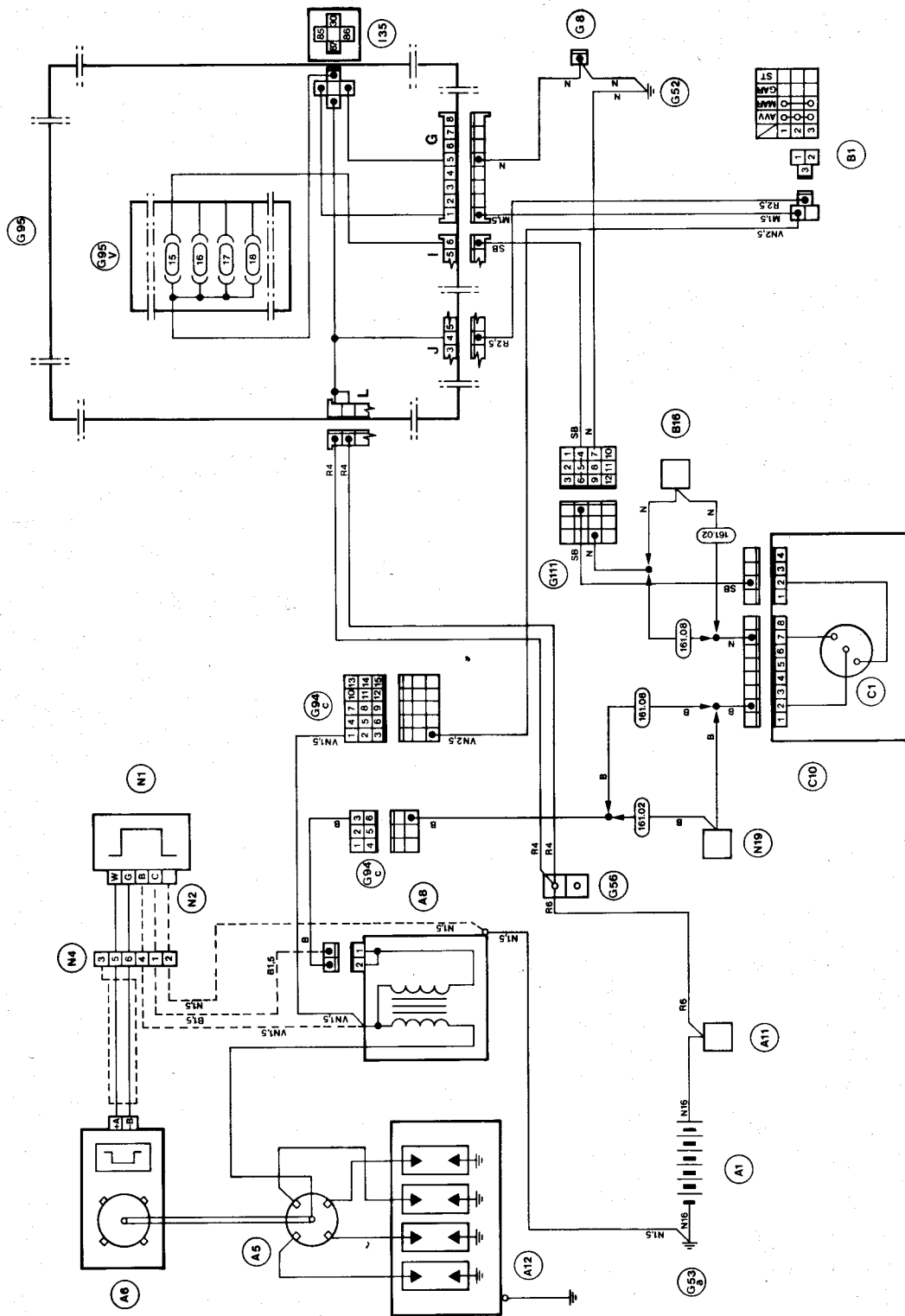

- | | | |
|---|---|---|
| <p>A1 Battery</p> <p>A5 Ignition distributor</p> <p>A6 Impulse generator</p> <p>A8 Ignition coil</p> <p>A11 Starter motor</p> <p>A12 Spark plugs</p> <p>B16 Cluster lighting dimmer rheostat</p> | <p>C1 Electronic rev-counter</p> <p>C10 Cluster</p> <p>G8 Single connector</p> <p>G52 Fusebox ground</p> <p>G53a Engine compartment ground - Right</p> <p>G56 Branch terminal board</p> <p>G94c Engine compartment connector - Right</p> <p>G95 Central fusebox</p> | <p>G95V Fuses</p> <p>G111 Connector for dashboard instruments wiring</p> <p>I35 Key-operated supply relay</p> <p>N1 Electronic ignition module</p> <p>N2 Connector for Marelli module</p> <p>N4 Connector for Bosch module</p> <p>N19 Performance gauge control unit</p> |
|---|---|---|

ELECTRICAL SYSTEM

ENGINE IGNITION **Giulietta** 1.6 1.8 2.0
Alfetta 1.6 1.8 2.0
GTV 2.0

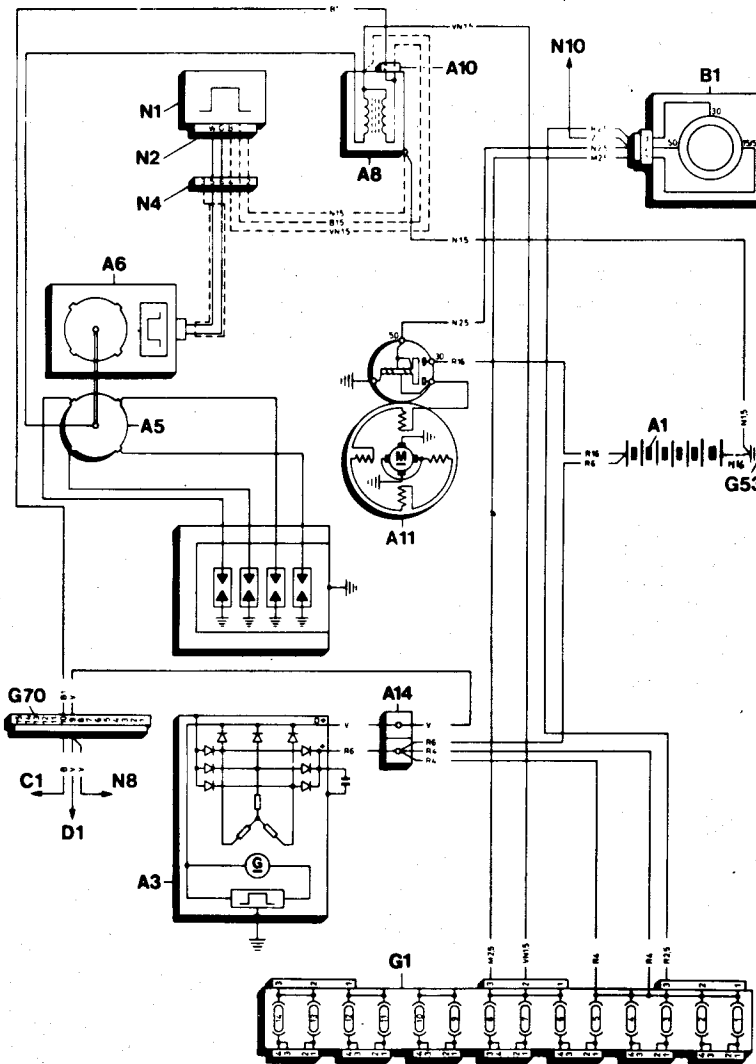

NOTE:

Leads shown in broken lines apply to BOSCH ignition system.
 On MARELLI ignition system these leads are pre-wired in coil-electronic unit.

- | | |
|--|---|
| A1 Battery | D1 Alternator warning lamp |
| A3 Alternator with integral voltage regulator | G1 Fuse unit |
| A5 Ignition distributor | G53 Engine compartment ground |
| A6 Pulse generator | G70 Connection C with cabling loom |
| A8 Ignition coil | N1 Electronic ignition module |
| A10 Two-way coil connector | N2 Connector for Marelli module |
| A11 Starter | N4 Connector for Bosch module |
| A14 Alternator terminal block | N8 Alfa Romeo control |
| B1 Ignition switch | N10 Courtesy light timer |
| C1 Electronic rev-counter | |

ENGINE IGNITION, STARTER, CHARGING

ENGINE IGNITION Alfa 90 1.8 2.0 2.0 iniezione
 Alfetta 2.0

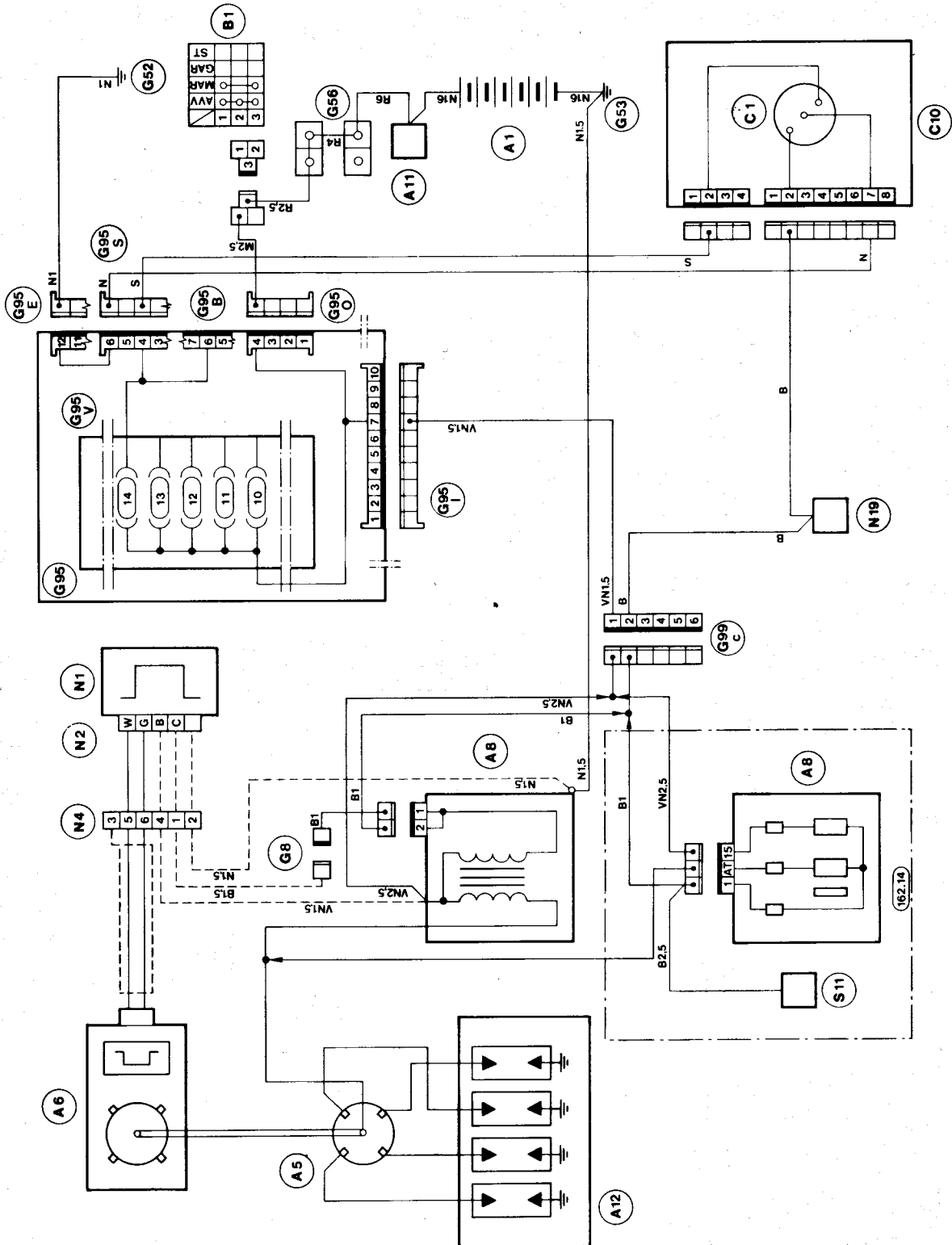

- A1 Battery
- A5 Ignition distributor
- A6 Impulse generator
- A8 Ignition coil
- A11 Starter motor
- A12 Spark plugs
- B1 Ignition switch
- C1 Electronic rev-counter
- C10 Instrument panel

- G8 Single connector
- G52 Fuse box earth
- G53 Engine compartment earth
- G56 Branch terminal board
- G95 Centralized fuse box
- G95B Switch connector
- G95E Console connector
- G95I DX interface connector
- G95O Ignition switch connector

- G95S Instrument panel connector
- G95V Fuses
- G99c Engine bulkhead C connector
- N1 Electronic ignition module
- N2 Connector for Marelli module
- N4 Connector for Bosch module
- N19 Performance gauge
- S11 Motronic unit

ENGINE IGNITION, STARTER, CHARGING

ENGINE IGNITION Alfa 90 2.0 6V iniezione

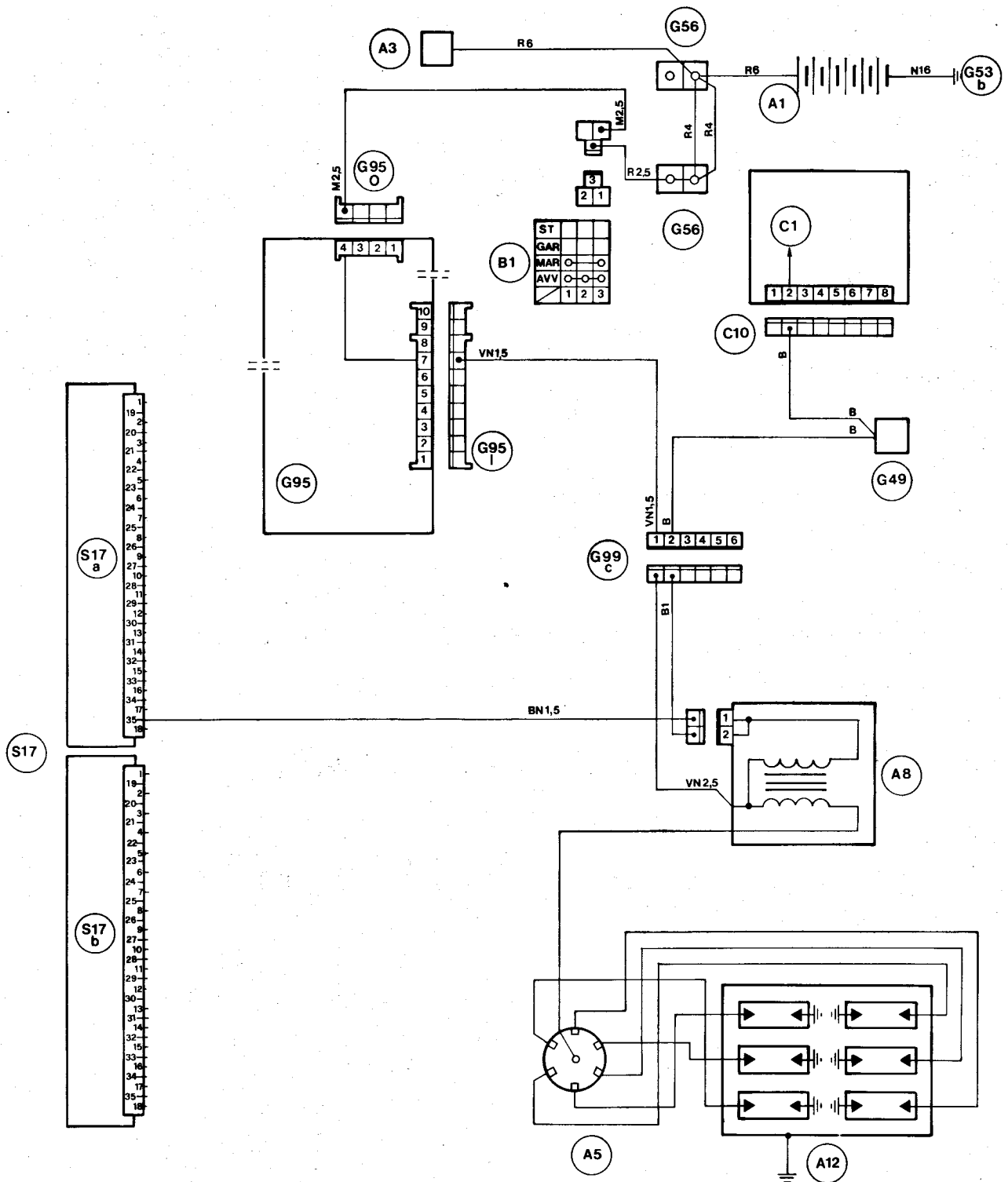

- | | | |
|--|---|---|
| A1 Battery | C1 Electronic rev-counter | G950 Ignition switch connection |
| A3 Alternator with electronic regulator | C10 Cluster | G99c Engine bulkhead C connector |
| A5 Ignition distributor | G49 Connection | S17 ECU |
| A8 Ignition coil | G53b Engine compartment ground, left | S17a ECU WHITE connector |
| A12 Spark plugs | G95 Central fusebox | S17b ECU BLACK connector |
| B1 Ignition switch | G951 Interface connector, right | |

ENGINE IGNITION, STARTER, CHARGING

ENGINE IGNITION Alfa 75  6V iniezione

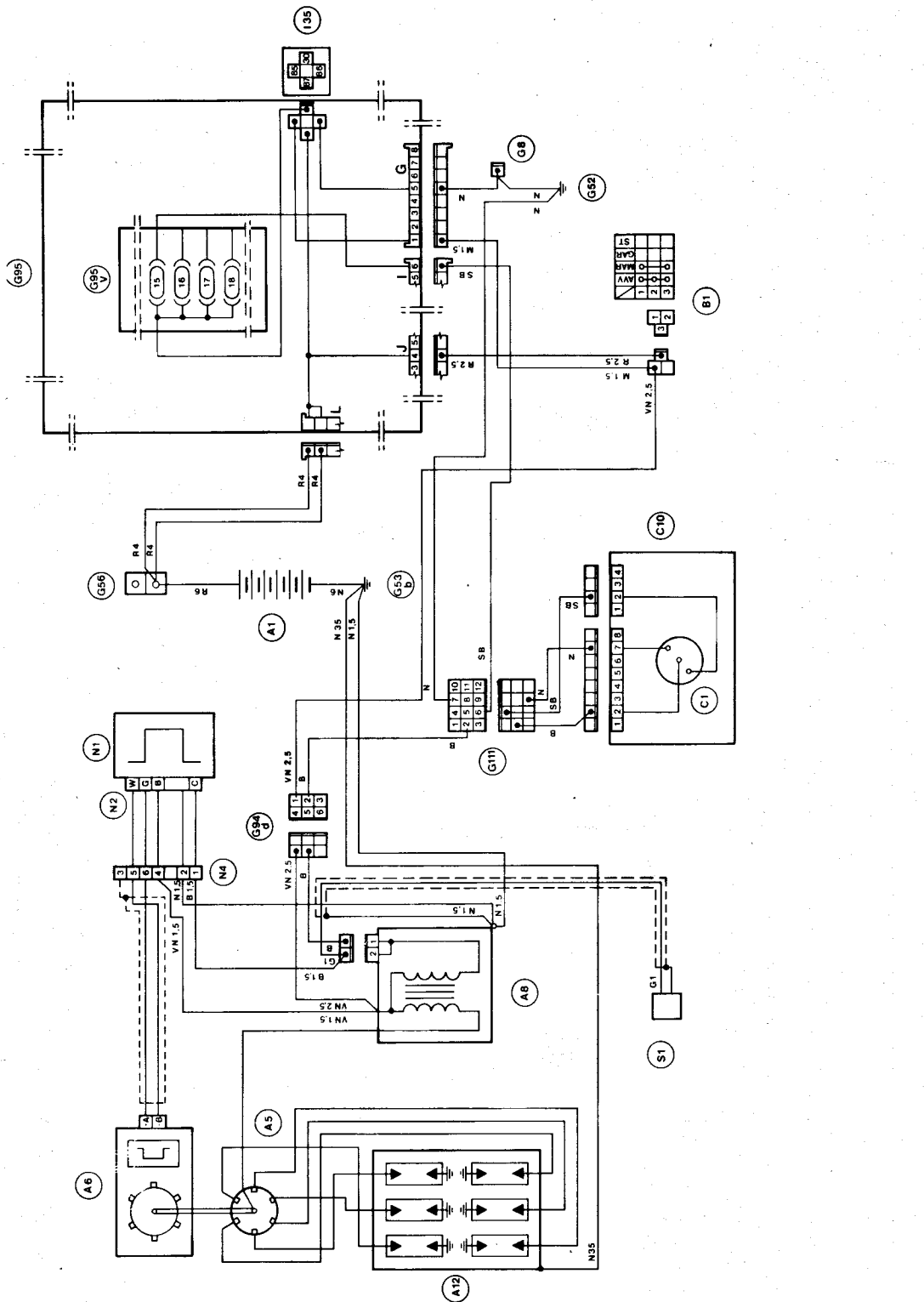

- | | |
|--|--|
| A1 Battery | G56 Branch terminal board |
| A5 Ignition distributor | G94d Engine compartment connector - Left |
| A6 Impulse generator | G95 Central fusebox |
| A8 Ignition coil | G95V Fuse |
| A12 Spark plugs | G111 Connector for dashboard instruments wiring |
| B1 Ignition switch | I35 Key-operated supply relay |
| C1 Electronic rev-counter | N1 Electronic ignition module |
| C10 Cluster | N2 Connector for Marelli module |
| G8 Single connector | N4 Connector for Bosch module |
| G52 Fusebox ground | S1 Injection control unit |
| G53b Engine compartment ground - Left | |

ENGINE IGNITION, STARTER, CHARGING

ENGINE IGNITION **GTV 6 2.5**

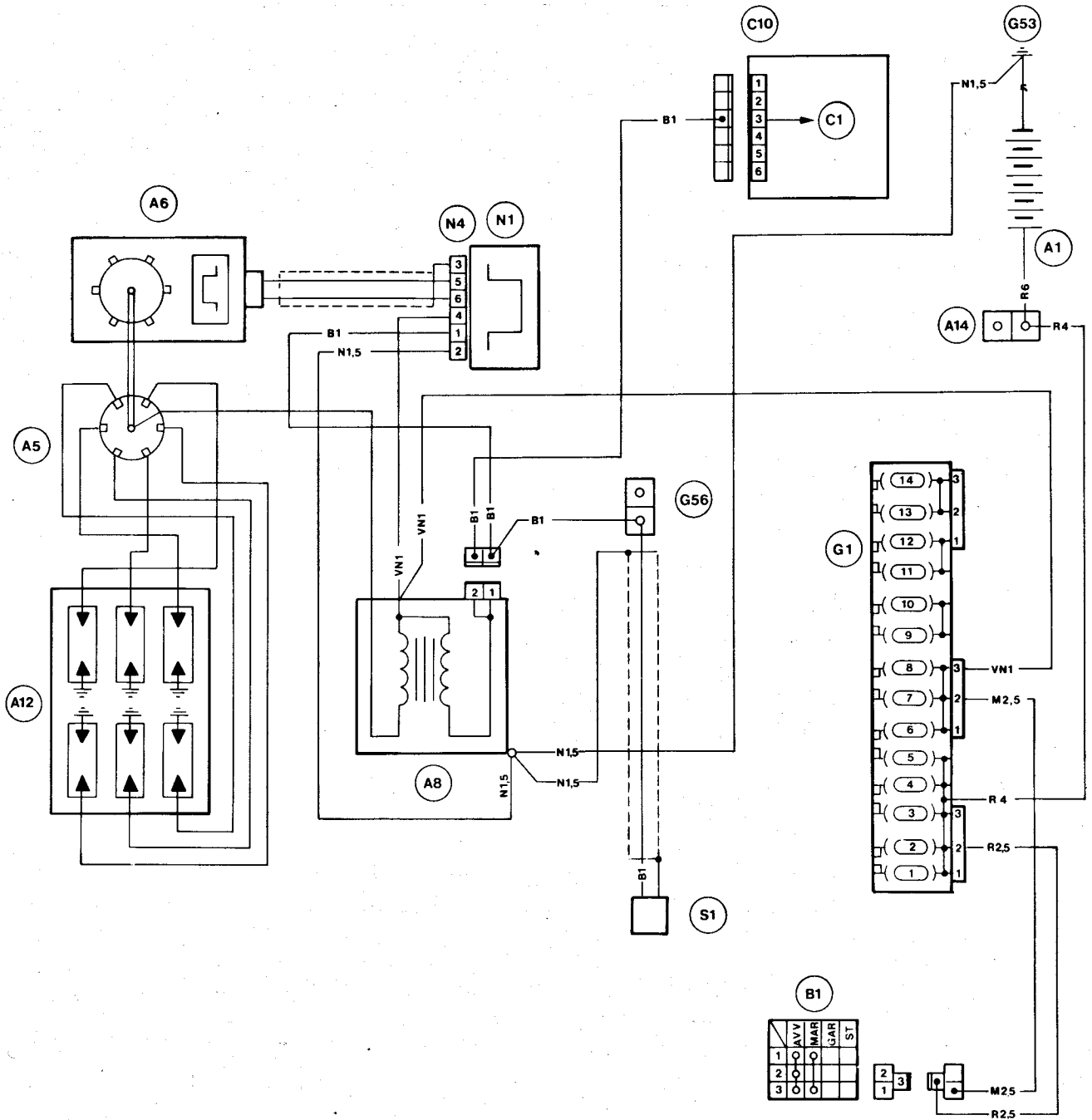

- A1** Battery
- A5** Ignition distributor
- A6** Impulse generator
- A8** Ignition coil
- A12** Spark plugs
- A14** Alternator cable terminal board
- B1** Ignition switch
- C1** Electronic rev-counter

- C10** Cluster
- G1** Fusebox
- G53** Engine compartment ground
- G56** Branch terminal board
- N1** Electronic ignition module
- N4** Connector for Bosch module
- S1** Ignition control unit

ENGINE IGNITION, STARTER, CHARGING

ENGINE STARTER Alfa 75 6V iniezione

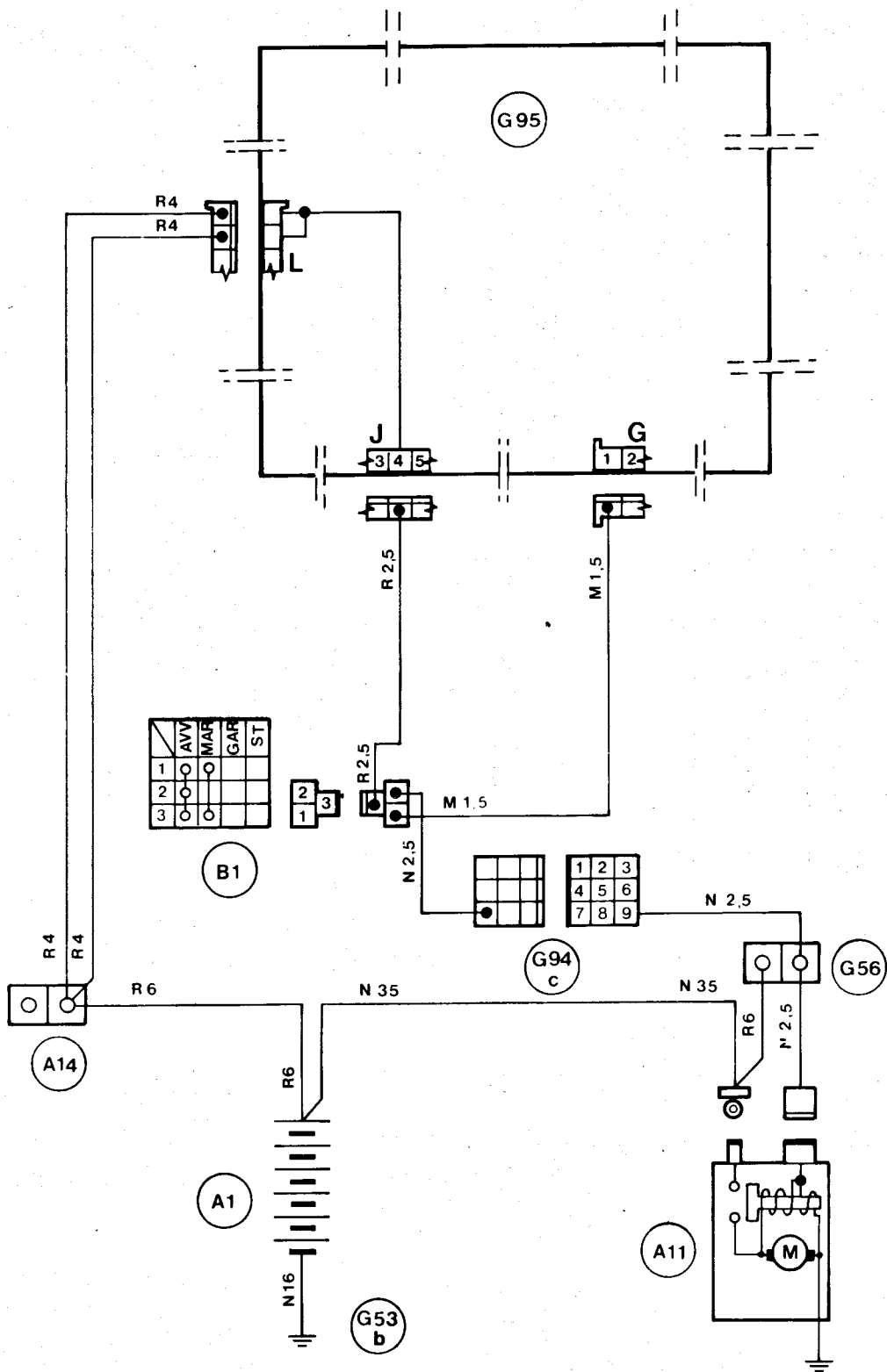

- A1 Battery
- A11 Starter motor
- A14 Alternator cable terminal board
- B1 Ignition switch

- G53b Engine compartment ground - Left
- G56 Branch terminal board
- G94c Engine compartment connector - Right
- G95 Central fusebox

ENGINE IGNITION, STARTER, CHARGING

ENGINE STARTER **GTV 6 2.5**

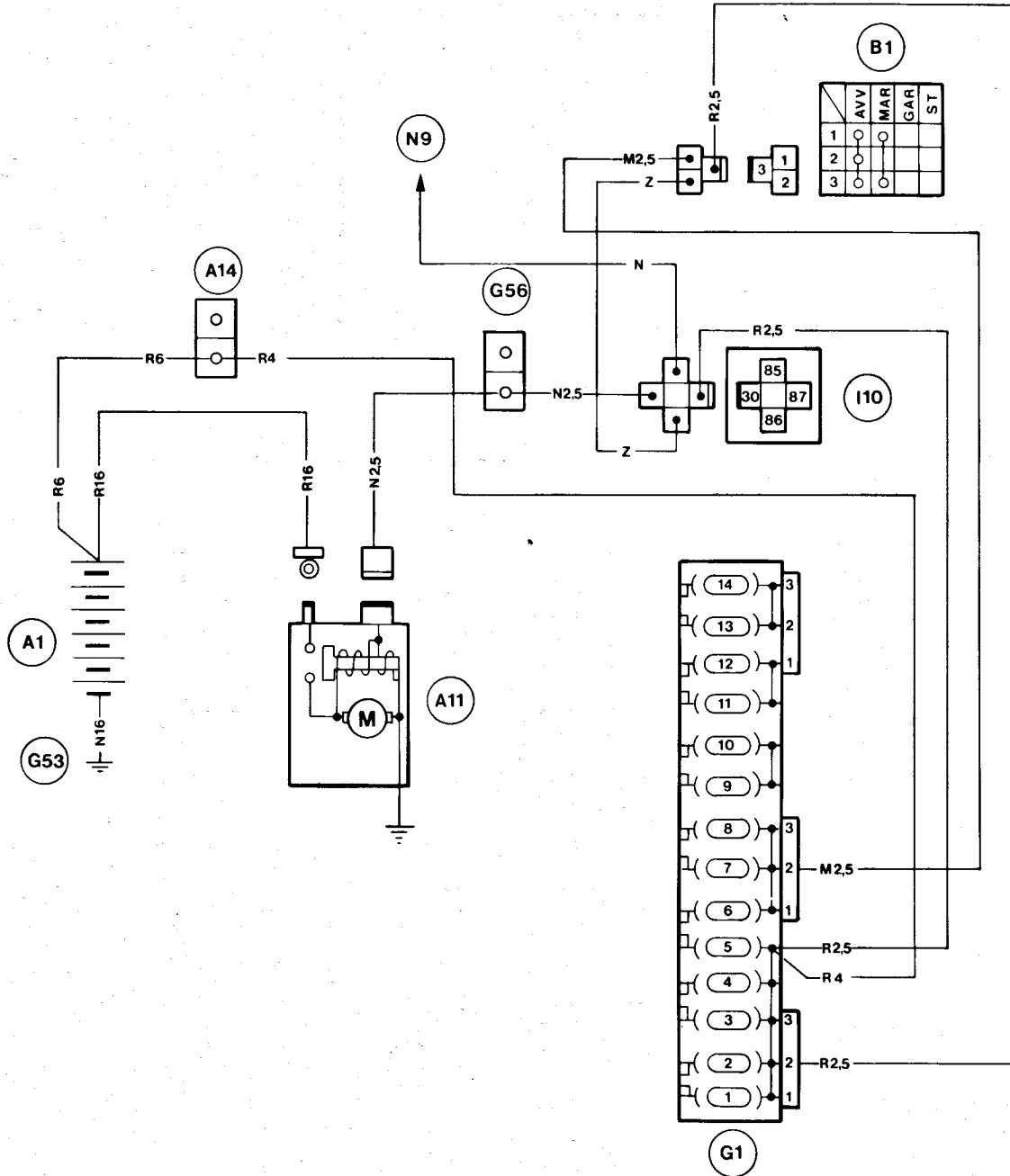

- A1** Battery
- A11** Starter motor
- A14** Alternator cable terminal board
- B1** Ignition switch
- G1** Fusebox

- G53** Engine compartment ground
- G56** Branch terminal board
- I10** Starter inhibitor relay
- N9** Brake pad wear control unit

ENGINE IGNITION, STARTER, CHARGING

ENGINE STARTER **Alfa 75** **1.6** **1.8** **2.0** **1.8 turbo**

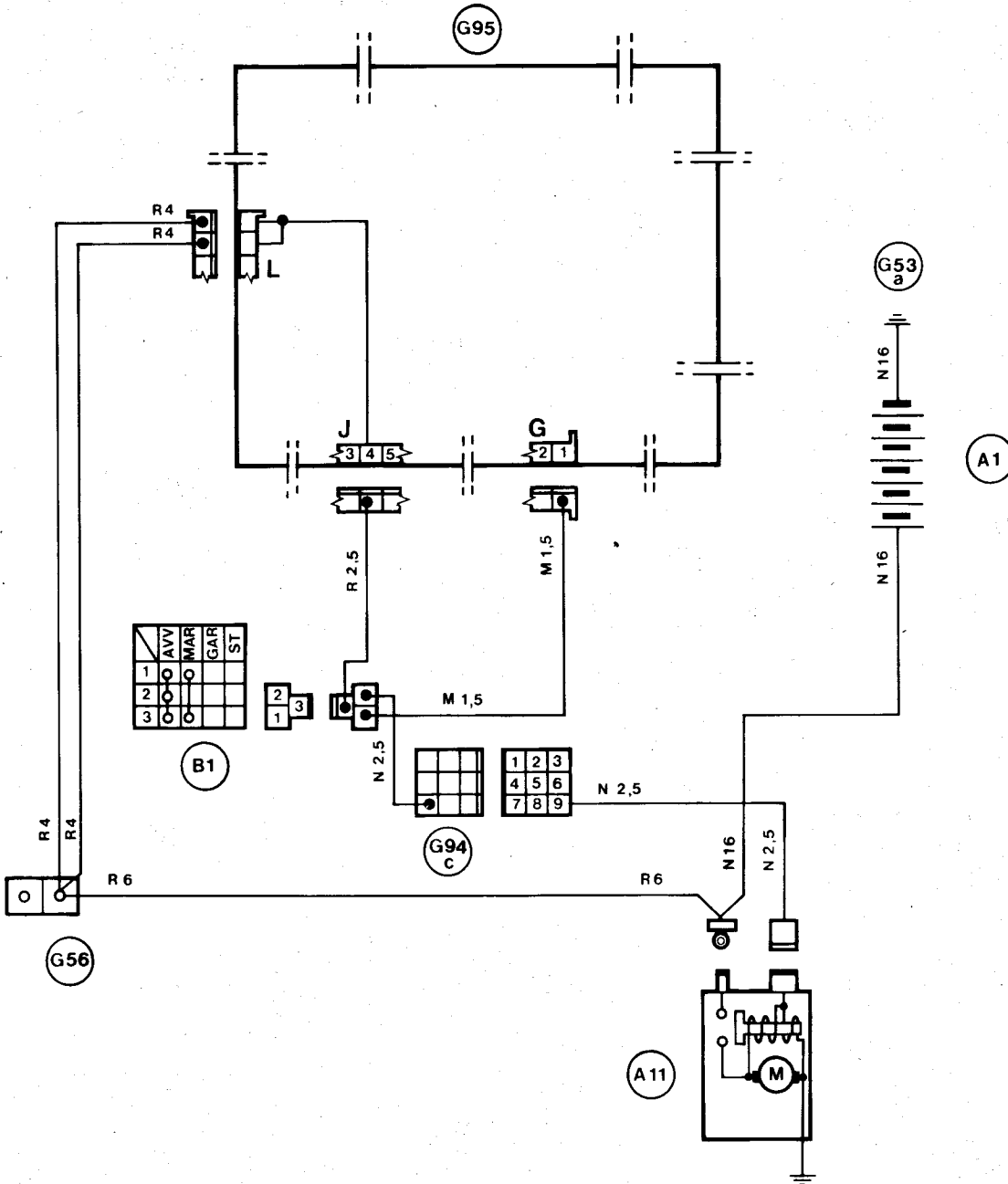

A1 Battery
A11 Starter motor
B1 Ignition switch
G53a Engine compartment ground - Right

G56 Branch terminal board
G94c Engine compartment connector - Right
G95 Central fusebox

ENGINE IGNITION, STARTER, CHARGING

ENGINE IGNITION Alfa 90 2.5  iniezione

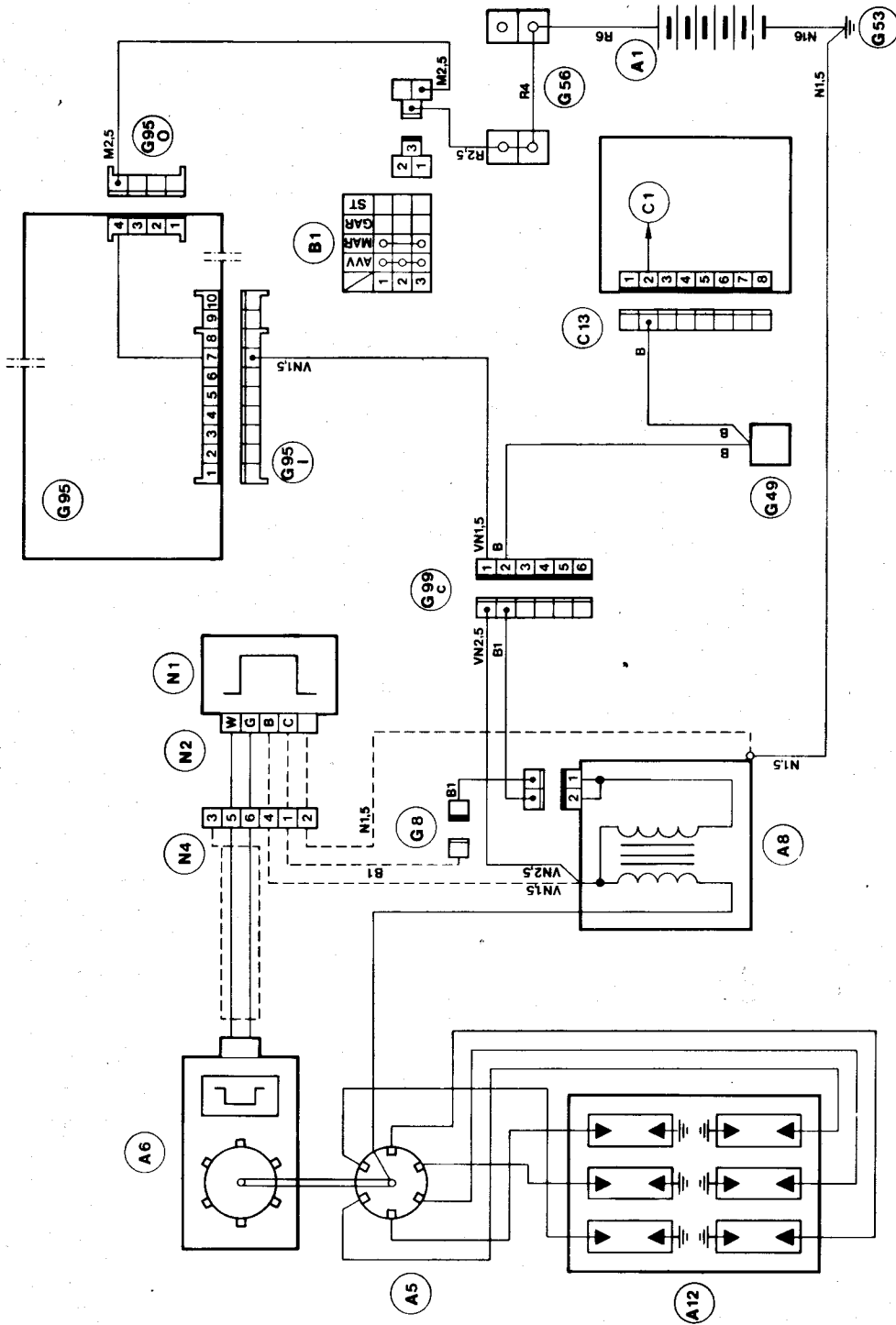

- | | |
|---|---|
| A1 Battery | G53 Engine compartment ground |
| A5 Ignition distributor | G56 Branch terminal board |
| A6 Impulse generator | G95 Centralized fuse box |
| A8 Ignition coil | G95I Interface connector - Right |
| A12 Spark plugs | G95O Ignition switch connector |
| B1 Ignition switch | G99c Engine bulkhead C connector |
| C1 Electronic rev-counter | N1 Electronic ignition module |
| C13 Opto-electronic instrument panel | N2 Connector for Marelli module |
| G8 Single connector | N4 Connector for Bosch module |
| G49 Provision for connection | |

ENGINE IGNITION, STARTER, CHARGING

ENGINE STARTER Alfa 90 1.8 2.0 2.0 Iniezione

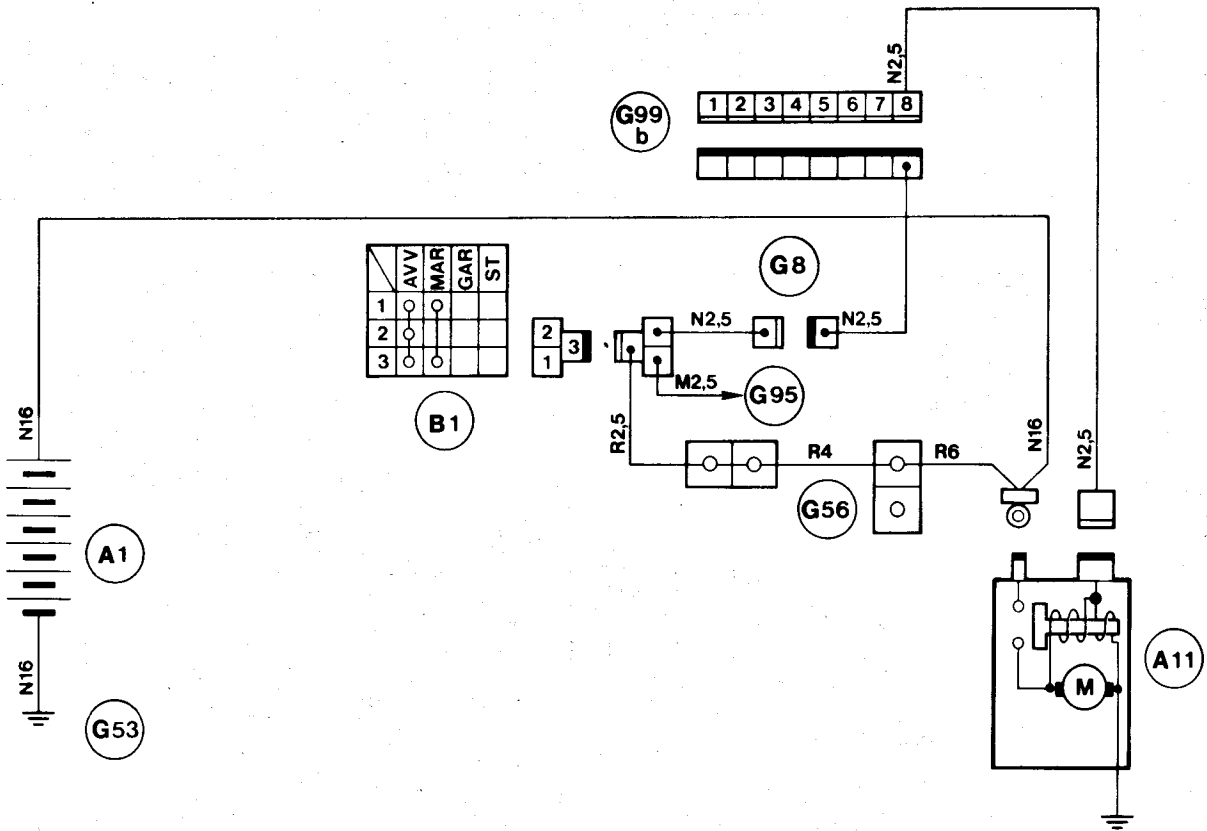

- A1** Battery
- A11** Starter motor
- B1** Ignition switch
- G8** Single connector

- G53** Engine compartment ground
- G56** Branch terminal board
- G95** Centralized fusebox
- G99b** Engine bulkhead B connector

ENGINE IGNITION, STARTER, CHARGING

ENGINE STARTER Alfa 90 2.0 6V Iniezione

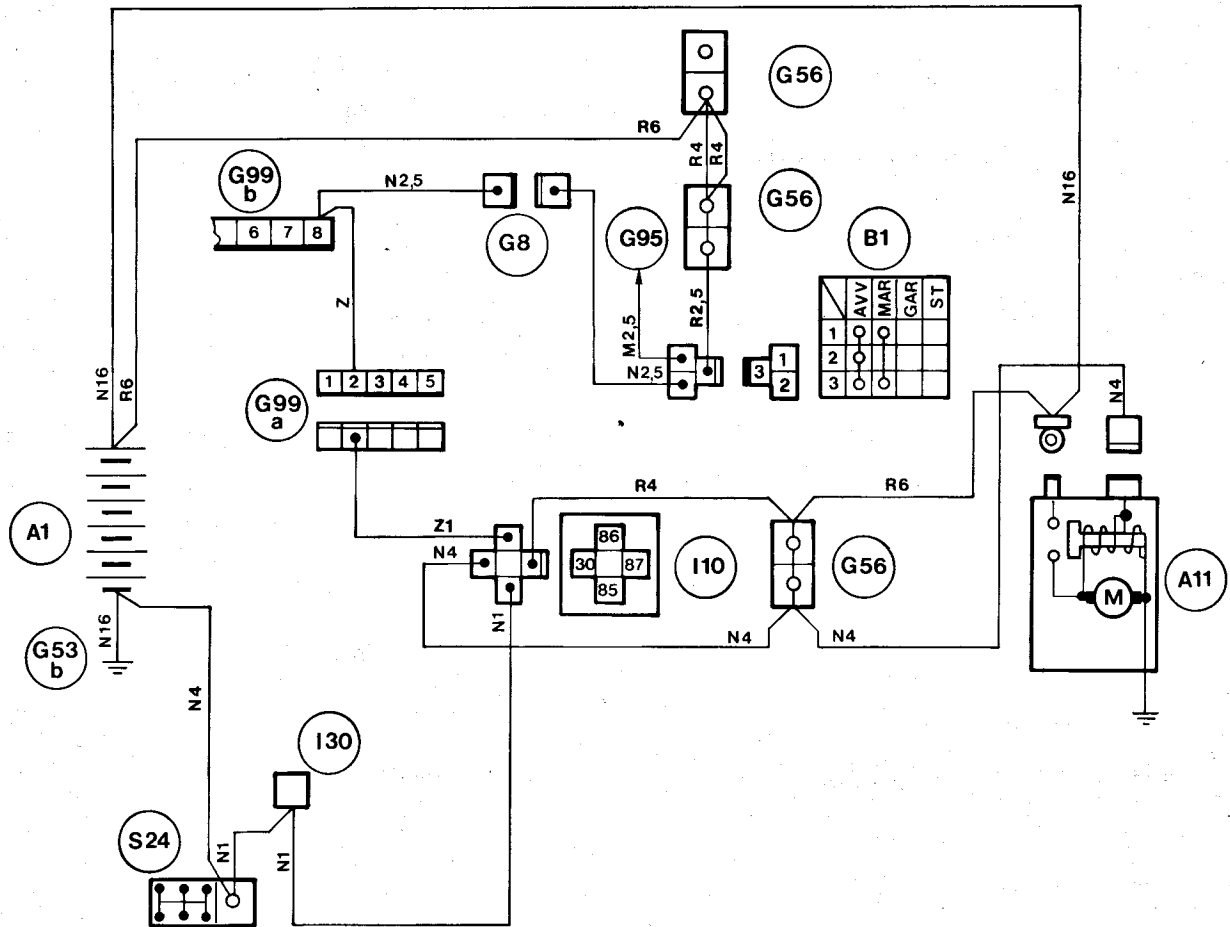

- A1 Battery
- A11 Starter motor
- B1 Ignition switch
- G8 Single connector
- G53b Engine compartment ground, left
- G56 Branch terminal board

- G95 Central fusebox
- G99a Engine bulkhead A connector
- G99b Engine bulkhead B connector
- I10 Starter inhibitor relay
- I30 CEM relay and diode
- S24 Injector terminal

ENGINE IGNITION, STARTER, CHARGING

ENGINE CHARGING Alfa 90 2.0 6V iniezione

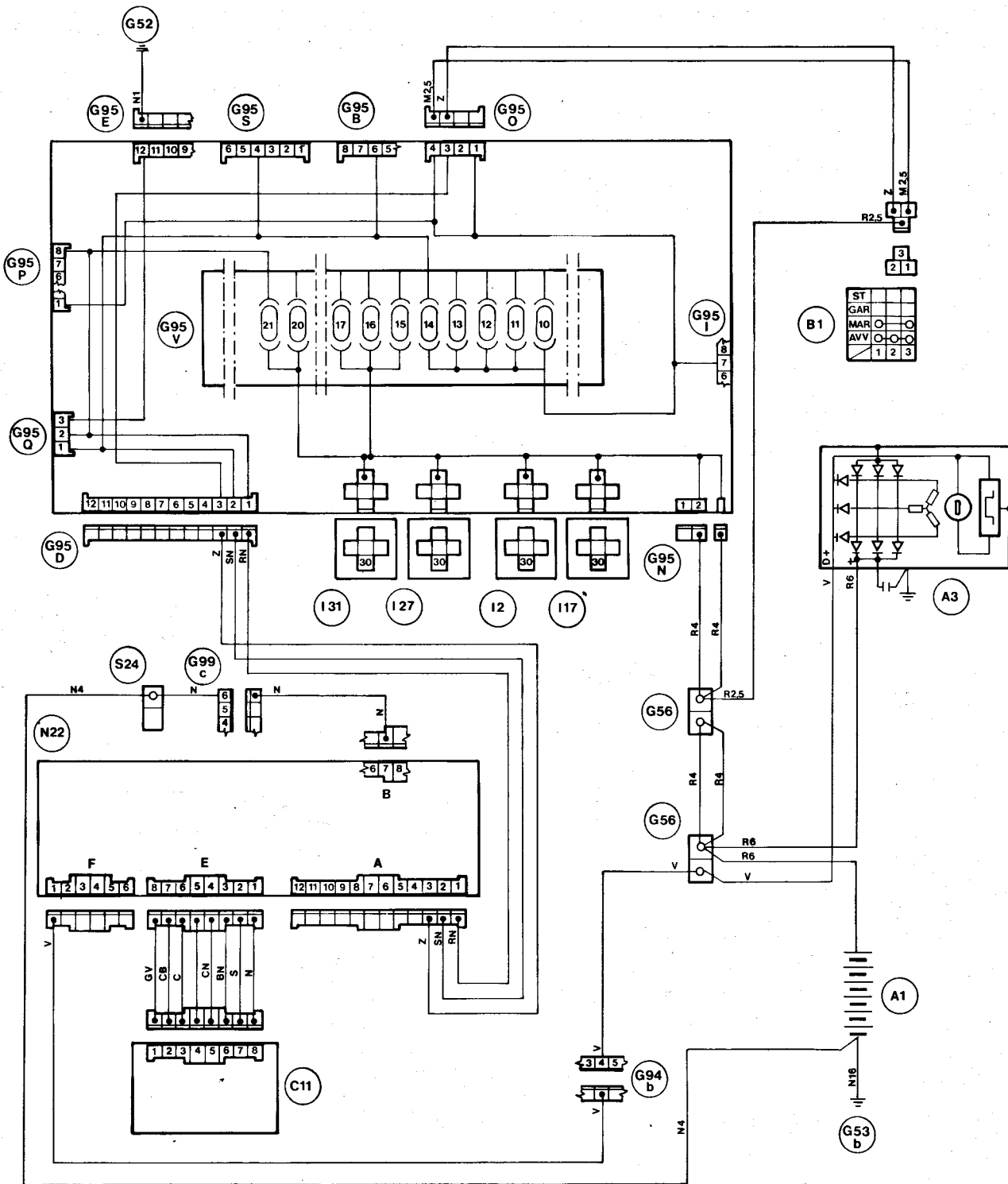

- A1** Battery
- A3** Alternator with electronic regulator
- B1** Ignition switch
- C11** Alfa Romeo Control display
- G52** Fusebox ground
- G53b** Engine compartment ground, left
- G94b** 8-way engine compartment connector

- G95B** Switch connector
- G95D** Alfa Romeo Control display connector
- G95E** Console connector
- G95I** Interface connector, right
- G95N** Battery connector
- G95O** Ignition switch connector
- G95P** Door circuit connector
- G95Q** Efficiency meter connector

- G95S** Instrument panel connector
- G95V** Fuses
- G99c** Engine bulkhead C connector
- I2** Heated rear window relay
- I17** Fog-light relay
- N22** Alfa Romeo Control display unit
- S24** Injector terminal

ENGINE IGNITION, STARTER, CHARGING

ENGINE CHARGING Alfa 75 1.3 turbo

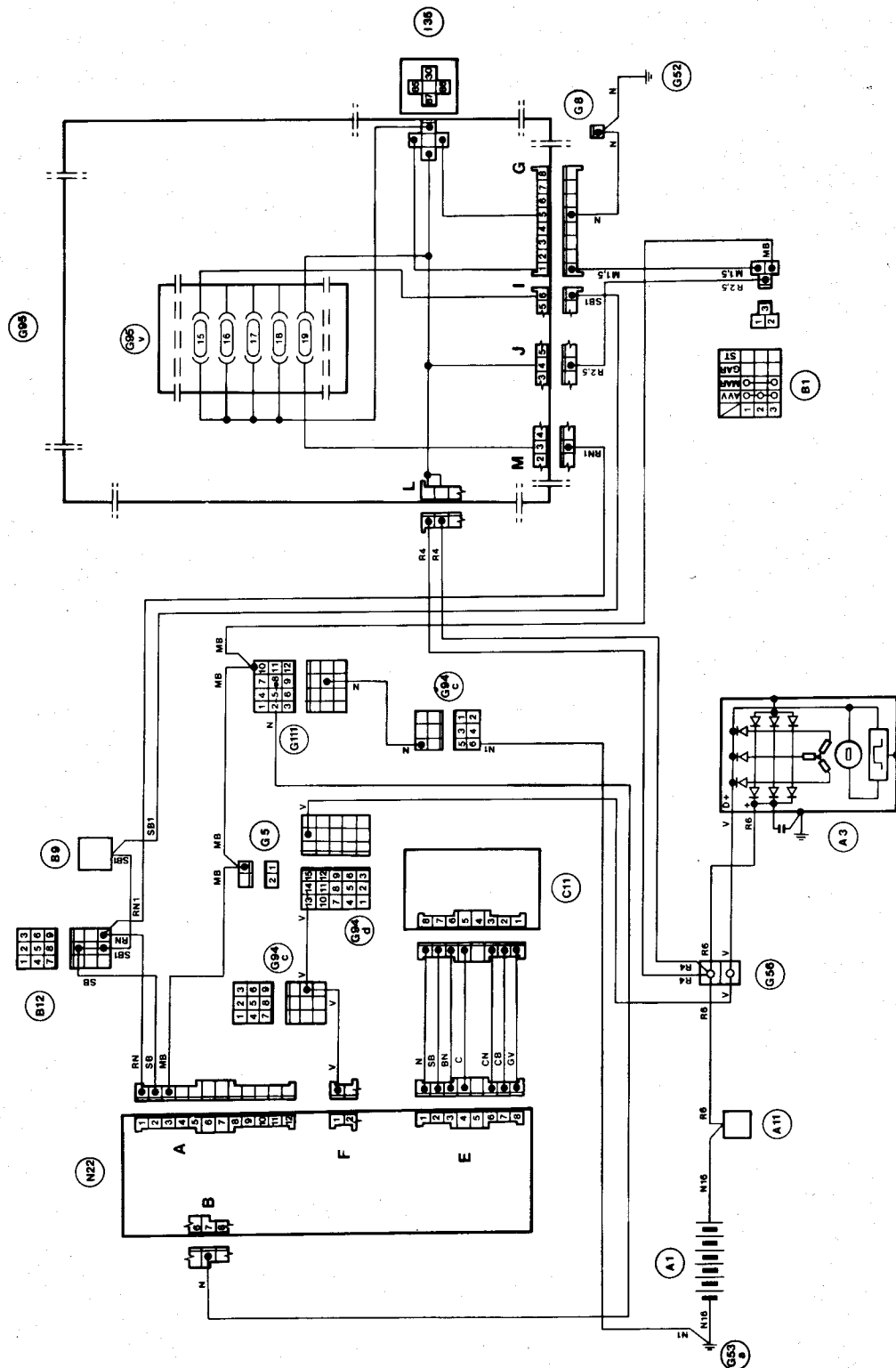

- | | |
|---|---|
| <ul style="list-style-type: none"> A1 Battery A3 Alternator with electronic regulator A11 Starter motor B1 Ignition switch B9 Heated rear window control switch B12 Road hazard lights control switch C11 Alfa Romeo Control display G5 Multiple connector G8 Single connector G52 Fusebox ground | <ul style="list-style-type: none"> G53a Engine compartment ground - Right G56 Branch terminal board G94c Engine compartment connector - Right G94d Engine compartment connector - Left G95 Central fusebox G95V Fuses G111 Connector for dashboard instruments wiring I35 Key-operated supply relay N22 Alfa Romeo Control control unit |
|---|---|

ENGINE IGNITION, STARTER, CHARGING

ENGINE CHARGING Alfa 75 1.6 1.8 2.0 6V Iniezione

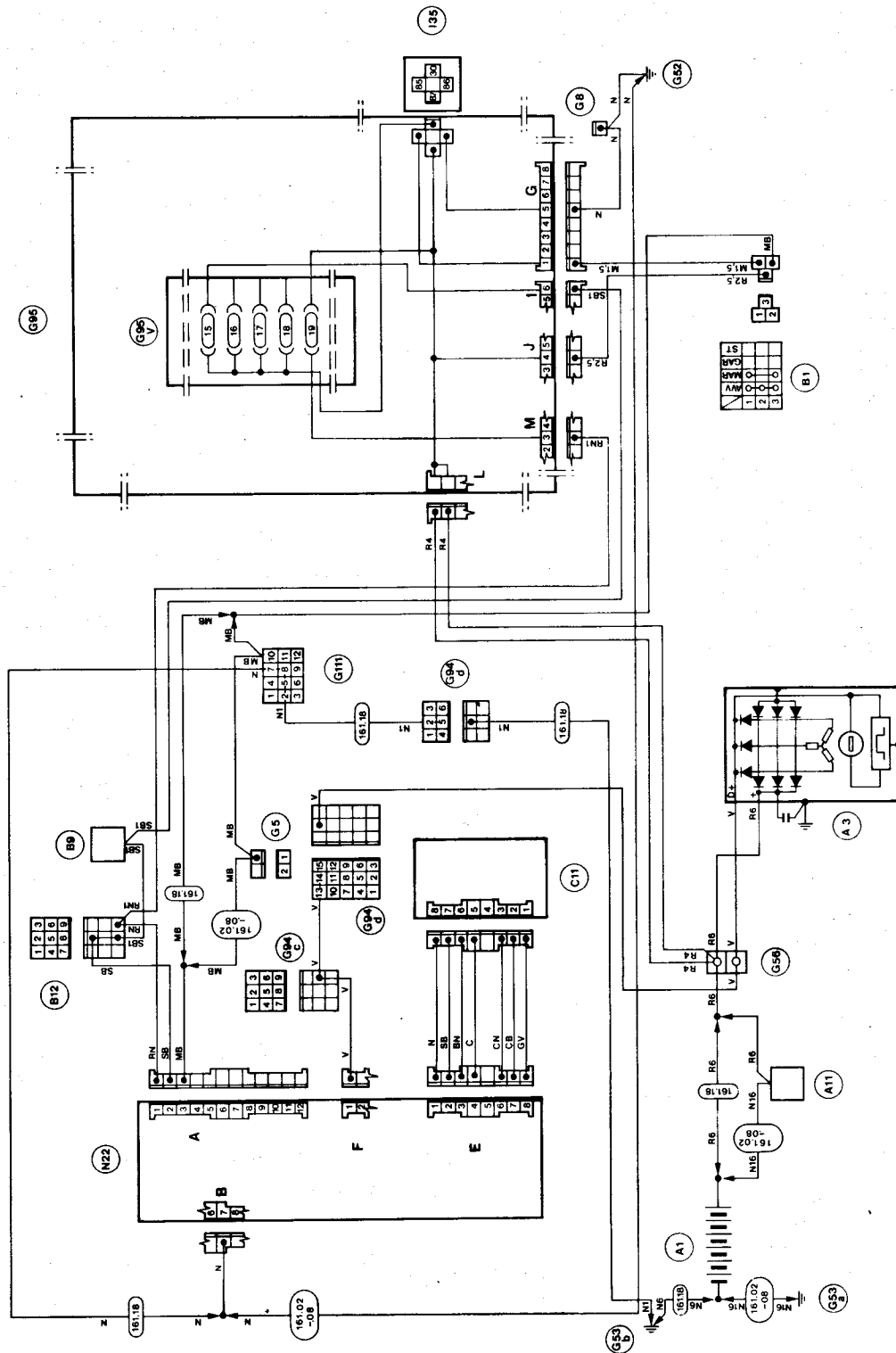

- A1 Battery
- A3 Alternator with electronic regulator
- A11 Starter motor
- B1 Ignition switch
- B9 Heated rear window control switch
- B12 Road hazard lights control switch
- C11 Alfa Romeo Control display
- G5 Multiple connector
- G8 Single connector
- G52 Fusebox ground

- G53a Engine compartment ground - Right
- G53b Engine compartment ground - Left
- G56 Branch terminal board
- G94c Engine compartment connector - Right
- G94d Engine compartment connector - Left
- G95 Central fusebox
- G95V Fuses
- G111 Connector for dashboard instruments wiring
- I35 Key-operated supply relay
- N22 Alfa Romeo Control control unit

ENGINE IGNITION, STARTER, CHARGING

ENGINE CHARGING GTV 6 2.5

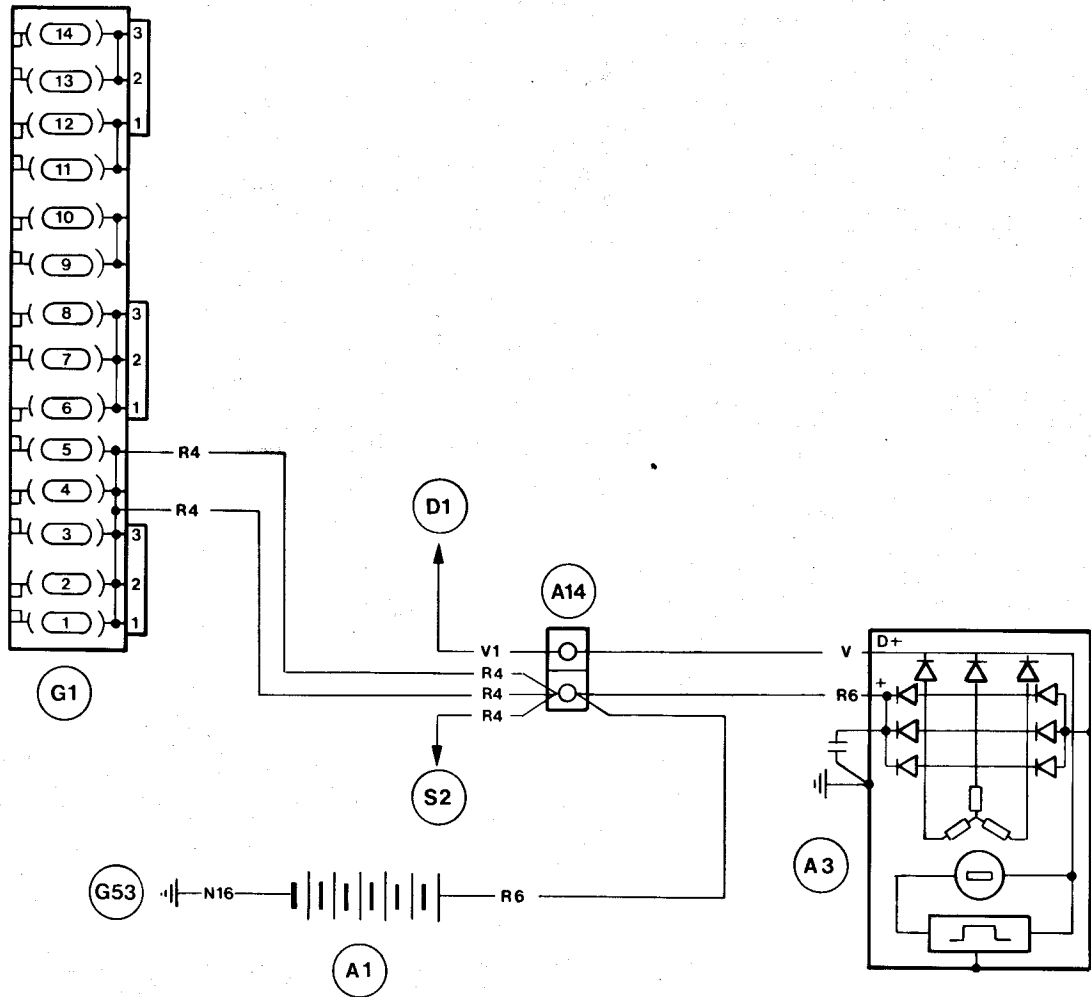

A1 Battery
A3 Alternator with electronic regulator
A14 Alternator cable terminal board
D1 Alternator warning lamp

G1 Fusebox
G53 Engine compartment ground
S2 Relay set

ENGINE IGNITION, STARTER, CHARGING

ENGINE CHARGING Alfa 90 1.8 2.0 2.0 iniezione 2.5 iniezione

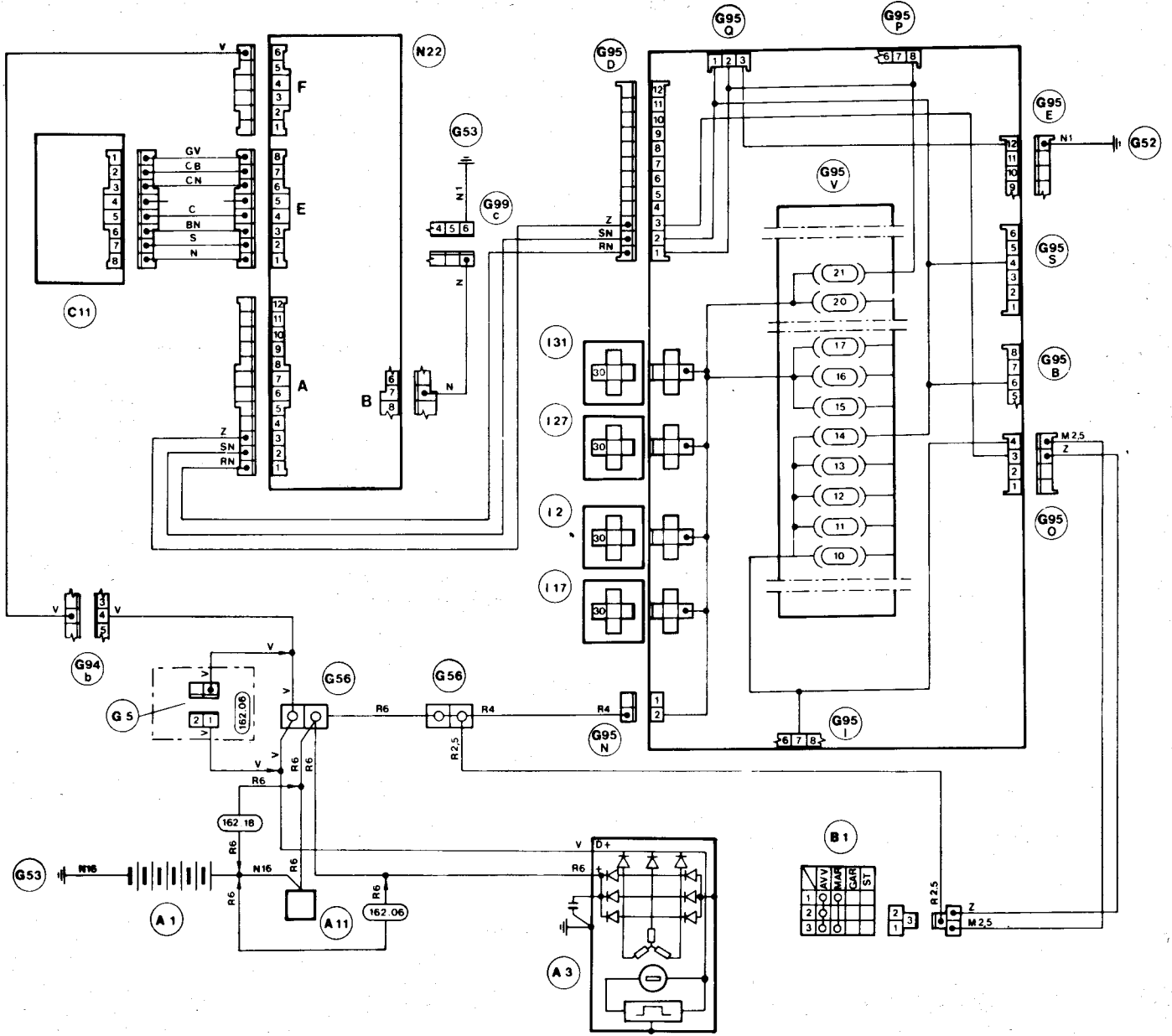

- A1** Battery
- A3** Alternator with electronic regulator
- A11** Starter motor
- B1** Ignition switch
- C11** Alfa Romeo control display
- G5** Multiple connector
- G52** Fusebox ground
- G53** Engine compartment ground
- G56** Branch terminal board
- G94b** 8-way engine compartment connector
- G95B** Switch connector
- G95D** Alfa Romeo control display connector
- G95E** Console connector

- G95I** Interface connector, right
- G95N** Battery connector
- G95O** Ignition switch connector
- G95P** Door circuit connector
- G95Q** Efficiency meter connector
- G95S** Instrument panel connector
- G95V** Fuses
- G99c** Engine bulkhead C connector
- I2** Heated rear window relay
- I17** Fog-light relay
- I27** Seat lift relay
- I31** Front electric window/heater fan relay
- N22** Alfa Romeo Control control unit

ENGINE IGNITION, STARTER, CHARGING

ENGINE STARTER Alfa 90 2.5 iniezione

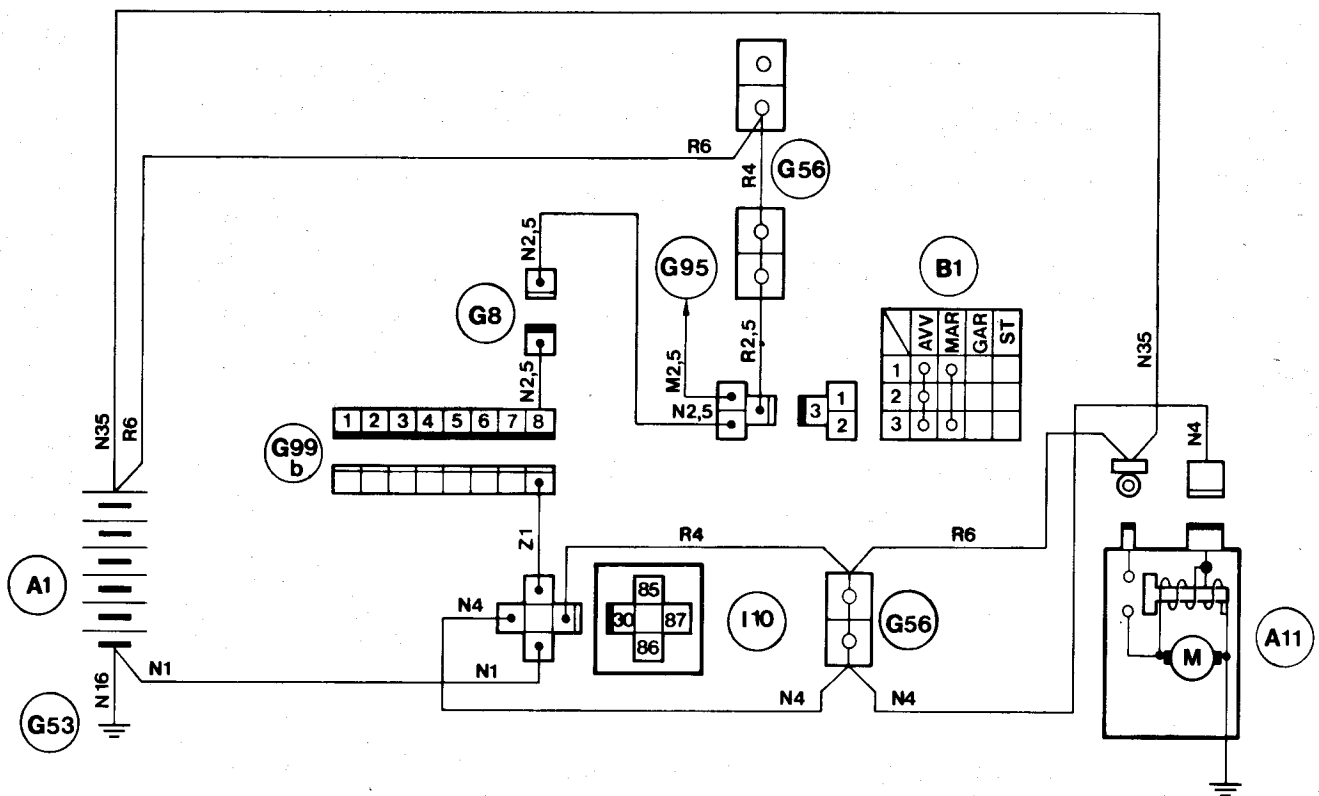

- A1 Battery
- A11 Starter motor
- B1 Ignition switch
- G8 Single connector
- G53 Engine compartment ground

- G56 Branch terminal board
- G95 Central fusebox
- G99b Engine bulkhead B connector
- I10 Starter inhibitor relay

ENGINE IGNITION, STARTER, CHARGING

ENGINE CHARGING **Alfa 90** **1.8** **2.0** **2.0 iniezione** **2.5** **iniezione**

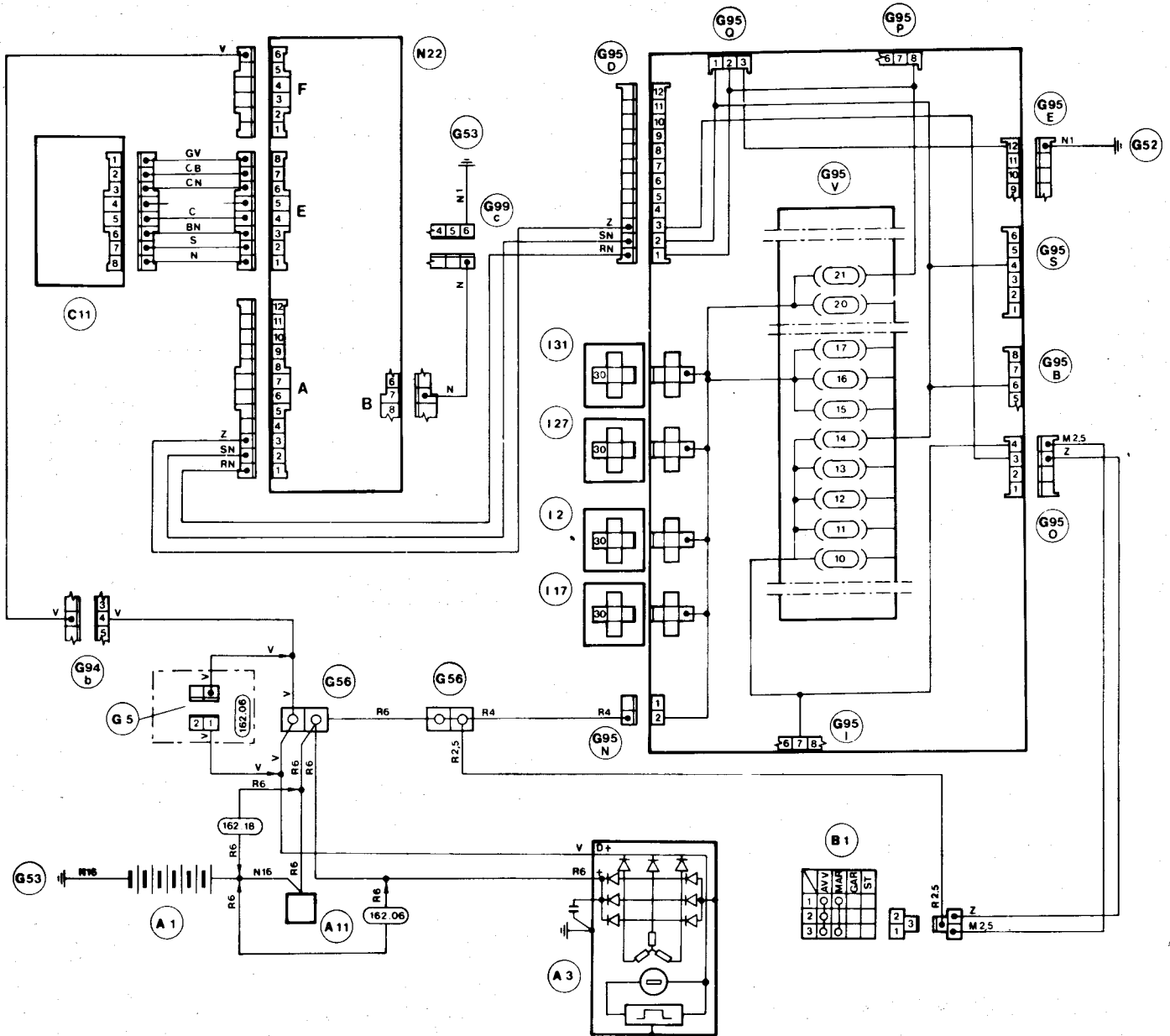

- A1** Battery
- A3** Alternator with electronic regulator
- A11** Starter motor
- B1** Ignition switch
- C11** Alfa Romeo control display
- G5** Multiple connector
- G52** Fusebox ground
- G53** Engine compartment ground
- G56** Branch terminal board
- G94b** 8-way engine compartment connector
- G95B** Switch connector
- G95D** Alfa Romeo control display connector
- G95E** Console connector

- G95I** Interface connector, right
- G95N** Battery connector
- G95O** Ignition switch connector
- G95P** Door circuit connector
- G95Q** Efficiency meter connector
- G95S** Instrument panel connector
- G95V** Fuses
- G99c** Engine bulkhead C connector
- I2** Heated rear window relay
- I17** Fog-light relay
- I27** Seat lift relay
- I31** Front electric window/heater fan relay
- N22** Alfa Romeo Control control unit

ENGINE IGNITION, STARTER, CHARGING

INSPECTION SPECIFICATIONS

DATA

Battery	Car model		
	1600	1800	2000
	113.48 - 113.49 - 117.18 161.00 - 161.01	113.50 - 113.51 - 117.17 161.02 - 161.03	117.13 - 117.14 - 117.01 162.02 - 162.12 - 162.14 113.17 - 113.18 161.08 - 161.09
Voltage (V)	12		
Capacity (Ah)	50 or 60 (1)		60 or 66 (1)
Discharge rating (A)	240 or 275 (1)		275 or 290 (1)
Electrolyte density (kg/dm ³)	1.28 to 0.01		

(1) Air conditioned version

Battery	Car model		
	2000	2500	1800
	162.10	162.46 - 161.80 - 161.190	161.34
Voltage (V)	12		
Capacity (Ah)	66		60
Discharge rating (A)	290		255
Electrolyte density (kg/dm ³)	1.28 to 0.01		

General requirements

FLUIDS AND LUBRICANTS

Description	Type	Recommended product	Quantity
Battery terminal	GREASE	Grease REINACH: E10 Tac Part No. 3671-69812	As necessary

ENGINE IGNITION, STARTER, CHARGING

COMPONENTS Alfa 75 Alfa 90 Alfetta GTV 6 2.5

Engine	Starter	Alternator (1)	Distributor	Coil/electronic module	Spark plug
1600 (016.00)	116.00.05.030.09 PARIS-RHONE D8E 145	116.10.05.060.08 BOSCH 0.120.489.549 K1→14V55A20	116.97.05.011.00 BOSCH 0.237.002.018	116.97.65.079.00 BOSCH 0.221.600.002	105.14.05.106.01 LODGE 2HL
1600 (061.00)	116.00.05.030.10 MAGNETI MARELLI E95-0,9/12				
1800 (016.78)	116.08.05.030.00 BOSCH 0.001.211.207 EF→12V-0,7CV				
1800 (062.02)	116.08.05.030.03 DUCELLIER DmE124P1				
	113.48.05.030.00 (3) BOSCH 12V-0,8 kW				
2000 (016.55)	105.12.05.030.03 BOSCH 0.001.311.110 GF→12V-1,1CV	116.10.05.060.12 PARIS-RHONE A13R192	116.97.05.011.01 MAGNETI MARELLI SM802BX	116.55.65.079.02 MAGNETI MARELLI AEI200B	
1600 (061.00) 2000 (062.12)	117.01.05.030.00 BOSCH 0.001.108.024 12V-1,4 kW				
2000 (017.13) (5)	105.12.05.030.03 BOSCH 0.001.311.110 GF→12V-1,1CV	116.55.05.060.00 MAGNETI MARELLI	115.44.05.011.00 BOSCH 0.237.051.002	195.00.65.079.00 (2) BOSCH 0.221.122.344	119.00.05.106.01 SILVER LODGE 2HL-E
2000 (017.13) (6)	117.01.05.030.000 BOSCH 0.001.108.024 12V-1,4 kW 116.55.05.030.03 BOSCH 0.001.108.011 12V-1,4 kW				
2000 (062.10)	116.46.05.030.00 BOSCH 0.001.311.139 GF→12V-1,1kW	119.13.05.060.00 BOSCH 0.120.489.715.716 K1→14V65A21	195.15.05.011.00 (4) MAGNETI MARELLI DT454A	117.20.05.079.00 (2) MAGNETI MARELLI BAE209C	105.14.05.106.01 LODGE 2HL
2500 (016.46)	116.46.05.030.00 BOSCH 0.001.311.139 GF→12V-1,5CV		116.46.05.011.00 BOSCH 0.237.301.008	116.97.65.079.00 BOSCH 0.221.600.002	119.00.05.106.01 SILVER LODGE 2HL-E

- (1) Integral electronic voltage regulator
- (2) Coil
- (3) Models 161.00 - 161.02 and 162.02 only
- (4) Integral Master Reset sensor
- (5) Models 117.13
- (6) Models 162.14

ENGINE IGNITION, STARTER, CHARGING

COMPONENTS (GIULIETTA)

Engine	Starter	Alternator [Regulator]	Distributor	Coil	Spark plug
1600 (016.00)	116.08.05.030.00 BOSCH 0.001.211.207 EF→12V0,7CV	116.10.05.060.03 BOSCH 0.120.400.848 K1→14V45A22 [105.36.65.028.00] BOSCH AD1	116.55.05.011.00 BOSCH 0.231.170.229	105.26.65.079.00 BOSCH 0.221.119.008	
	116.00.05.030.10 MARELLI E95-0,9/12	116.10.05.060.01 PARIS RHONE A13R121 [116.10.65.028.01] PARIS RHONE AYC2112		116.42.65.079.00 MARELLI BE 200H	
	116.00.05.030.09 PARIS RHONE D8E 145	116.10.05.060.18 SEV MARCHAL A14/55A 71212702 [116.10.65.028.05] SEV MARCHAL-blue dot		105.48.65.079.00 KLITZ G 53 SB	
	116.00.05.030.09 (1) PARIS RHONE D8E 145	116.10.05.060.08 (2) BOSCH 0.120.489.549 K1→14V55A20		105.12.65.079.02 SEV MARCHAL-3H	
1800 (016.78)	116.08.05.030.03 (1) DUCELLIER DmE 124P1	116.10.05.060.12 (2) PARIS RHONE A13R192	116.55.05.011.01 MARELLI S168BX	105.12.65.079.03 ISKRA ATA-0105	105.14.05.106.01 LODGE 2HL
		116.55.05.060.00 (2) MARELLI	116.55.05.011.03 DUCELLIER 4533 A	105.12.65.079.01 DUCELLIER 2792 A	
2000 (016.55)	105.12.05.030.03 BOSCH 0.001.311.110 GE→12V1,1PS	116.10.05.060.08 (2) BOSCH 0.120.489.549 K1→14V55A20	116.55.05.011.00 BOSCH 0.231.170.229	116.33.65.079.00 MARELLI BZR 202 B	105.14.05.106.01 LODGE 2HL
	116.55.05.030.00 PARIS RHONE D10E70	116.10.05.060.12 (2) PARIS RHONE A13R192	116.55.05.011.01 MARELLI S168BX	116.55.65.079.01 BOSCH 0.221.119.044	
	116.55.05.030.01 MARELLI E 100-1,3-1,2	116.55.060.00 (2) MARELLI	116.55.05.011.03 DUCELLIER 4533A		

(1) 1600 engine only (016.00)

(2) Integral electronic voltage regulator

Electronic ignition

Engine	Coil with electronic module	Magnetic distributor	
1600 (016.00)	116.55.65.079.02 MAGNETI MARELLI AEI 200 B	116.97.05.011.01 MAGNETI MARELLI SM 802 EX	
1800 (016.78)	116.97.65.079.00 BOSCH 0.221.600.002	116.97.05.011.00 BOSCH 0.237.02.018	
2000 (016.55)			
2500 (016.46)		—	

ENGINE IGNITION, STARTER, CHARGING

COMPONENTS GTV 2.0

Engine	Starter	Alternator [Regulator]	Distributor	Coil	Spark plug
2000 (016.55)	105.12.05.030.03 BOSCH 0.001.311.110 GF→12V-1,1PS	116.10.05.060.03 BOSCH 0.120.400.848 K1→14V45A22 [105.36.65.028.00] BOSCH AD1	116.55.05.011.00 BOSCH 0.231.170.229	116.55.65.079.00 BOSCH 0.221.119.044	105.14.05.106.01 LODGE 2HL
		116.10.05.060.01 PARIS RHONE A13R121 [116.10.65.028.01] PARIS RHONE AYC2112	116.55.05.011.01 MARELLI S168BX	116.33.65.079.01 MARELLI BZR202B	
	116.55.05.030.00 PARIS RHONE D10E70	116.10.05.060.18 SEV MARCHAL A14/55A 71212702 [116.10.65.028.05] SEV MARCHAL-blue dot	116.55.05.011.03 DUCELLIER 4533 A	116.55.65.079.01 BOSCH 0.221.119.044	
		116.10.05.060.08 (1) BOSCH 0.120.489.549 K1→14V55A20	116.97.05.011.01 (2) MARELLI SM802BX	116.55.65.079.02 (3) MARELLI AEI 200B	
	116.55.05.030.10 MARELLI E100-1,3-1,2	116.10.05.060.12 (1) PARIS RHONE A13R192	116.97.05.011.00 (2) BOSCH 0.237.002.018	116.97.65.079.00 (3) BOSCH 0.221.600.002	
		116.55.05.060.00 (1) MARELLI			

- (1) Integral electronic voltage regulator
 (2) Electronic ignition engines
 (3) Coils with electronic module for electronic ignition

COMPONENTS Alfa 75 1.8 turbo

Engine	Starter	Alternator (1)	Distributor	Coil/electronic module	Spark plug
1800 (061.34)	116.00.05.030.09 PARIS-RHONE D8E 145	116.10.05.060.08 BOSCH 0.120.489.549 K1→14V55A20	195.05.05.011.02 BOSCH 0.237.520.001	116.97.65.079.00 BOSCH 0.221.600.002	195.05.05.106.00 TURBO LODGE 2XL
	116.00.05.030.10 MAGNETI MARELLI E95-0,9/12				
	116.08.05.030.00 BOSCH 0.001.211.207 EF→12V-0,8CV	116.10.05.060.12 PARIS-RHONE A13R192			
	116.08.05.030.03 DUCELLIER DmE124P1	116.55.05.060.00 MAGNETI MARELLI			
	113.48.05.030.00 BOSCH 12V-0,8 kW				

- (1) Integral electronic voltage regulator

STARTING

BOSCH STARTER

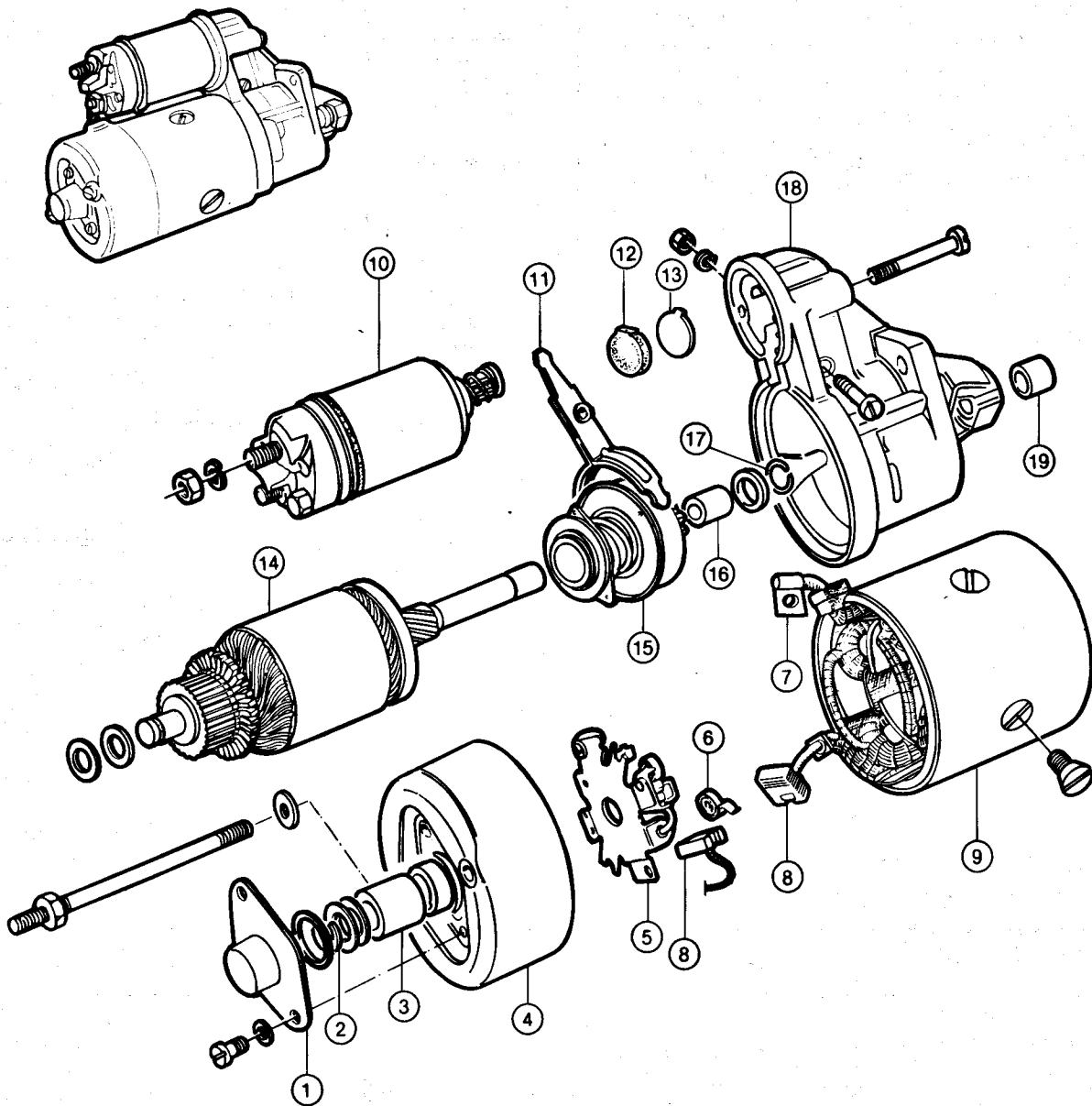

- 1. Dust excluder
- 2. Retaining ring
- 3. Bush
- 4. Commutator end support
- 5. Brush carrier
- 6. Brush spring
- 7. Field winding terminal
- 8. Brush
- 9. Yoke
- 10. Solenoid

- 11. Fork
- 12. Rubber plate
- 13. Backing plate
- 14. Armature
- 15. Starter drive
- 16. Bush
- 17. Pinion stop ring
- 18. Drive end support
- 19. Bush

ENGINE IGNITION, STARTER, CHARGING

Starter	Alfa Romeo Part No.	117.01.05.030.00	113.48.05.030.00	116.55.05.030.00	116.00.05.030.09
	Type	BOSCH 12 V 1.4 kW 0.001.108.024	BOSCH 12 V 0.8 kW	PARIS-RHONE D10E70	PARIS-RHONE D8E145 12 V 0.92 kW
Rated voltage	V	12	12	12	12
Rated output	kW (HP)	1.4 (1.9)	0.8 (1.1)	—	0.92 (1.25)
Max. brush length	mm (in)	11 (0.43)	11 (0.43)	9 (0.35)	9 (0.35)
Max. commutator eccentricity	mm (in)	0.06 (0.0024)	0.06 (0.0024)	0.05 (0.002)	0.05 (0.002)
Armature shaft running clearance	mm	0.02 to 0.05 (0.001 to 0.002)			
Running torque test (pinion meshing with braked ring gear)					
— Voltage	V	9	9.3	9.2	9.3
— Current consumption	A	≤315	≤250	≤280	≤230
— Speed	rpm	≥1700	≥1300	1450	1600 to 1700
— Torque	Nm (kgm) (ft.lb)	7.5 (0.75) (5.5)	6 (0.60) (4.4)	8 (0.8) (5.9)	5 (0.5) (3.7)
Lock torque test (pinion meshing with locked ring gear)					
— Voltage	V	4	7.1	6.8	7.2
— Current consumption	A	≤750	≤480	510	≤410
— Torque	Nm (kgm) (ft.lb)	≥16 (≥1.6) (≥11.8)	≥9.5 (≥0.95) (≥7.0)	20 (2) (14.8)	11.8 (1.2) (8.7)
Freewheel overrunning torque	Ncm (kgcm) (in.lb)	12 to 18 (1.2 to 1.8) (1.1 to 1.6)	12 to 18 (1.2 to 1.8) (1.1 to 1.6)	12 to 19 (1.2 to 1.9) (1.1 to 1.7)	12 to 19 (1.2 to 1.9) (1.1 to 1.7)
Starter-mounted switch test					
— Max. draw at rated voltage	A	≤40		≤55	≤55
— Min. cut-in voltage	V	≤7.8 (*)	≤7.8 (*)	≤12.5	—
Pinion teeth module		2.1167	2.1167	2.116	2.116

(*) At 20 to 25°C (68 to 77°F)

ENGINE IGNITION, STARTER, CHARGING

Starter	Alfa Romeo Part No.	116.46.05.030.00	116.55.05.030.03
	Type	BOSCH GF 12 V 1.4 kW 0.001.311.139	BOSCH 12 V 1.4 kW 0.001.108.011
Rated voltage	V	12	12
Rated output	kW (HP)	1.1 (1.5)	1.4 (1.9)
Max. brush length	mm (in)	— —	— —
Max. commutator eccentricity	mm (in)	— —	— —
Armature shaft running clearance	mm (in)	0.02 to 0.05 (0.001 to 0.002)	0.02 to 0.05 (0.001 to 0.002)
Running torque test (pinion meshing with braked ring gear)			
— Voltage	V	9	9
— Current consumption	A	290 max.	≤ 315
— Speed	rpm	1200 min.	≥ 1700
— Torque	Nm (kgm) (ft.lb)	8 (0.8) (5.9)	7.5 (0.75) (5.4)
Lock torque test (pinion meshing with locked ring gear)			
— Voltage	V	6	4
— Current consumption	A	500 max.	≤ 750
— Torque	Nm (kgm) (ft.lb)	13 (1.3) (9.6)	≥ 1.6 (≥ 0.16) (≥ 1.2)
Freewheel overrunning torque	Ncm (kgcm) (in.lb)	14 to 20 (1.4 to 2.0) (1.2 to 1.8)	12 to 18 (1.2 to 1.8) (1.04 to 1.6)
Starter-mounted switch test			
— Max. draw at rated voltage	A	38	≤ 40
— Min. cut-in voltage	V	7.5 (*) 9.5 (**)	≤ 7.8 (***)
Pinion teeth module		2.1167	2.1167

(*) At -20°C (-4°F)

(**) At +80°C (+176°F)

(***) At 20 to 25°C (68 to 77°F)

BOSCH DISTRIBUTOR Alfa 75 1.8 turbo

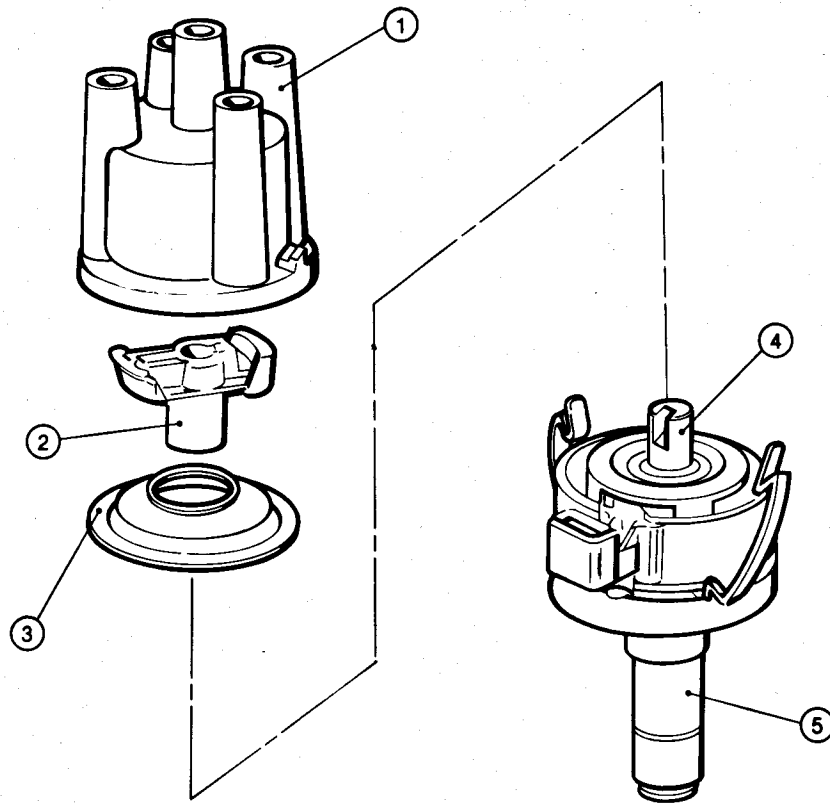

1. Cap
2. Rotor arm
3. Dust cover
4. Drive shaft
5. Distributor body

BOSCH DISTRIBUTOR



Clamp distributor in a vice provided with protective jaw liners.

a. Remove cap ① and take off rotor arm ② with associated rpm limiter and then the lubricating felt.

The rpm limiter is a centrifugal device situated on the head of the rotor arm used to cut off ignition when the engine exceeds 6300 ± 150 rpm.

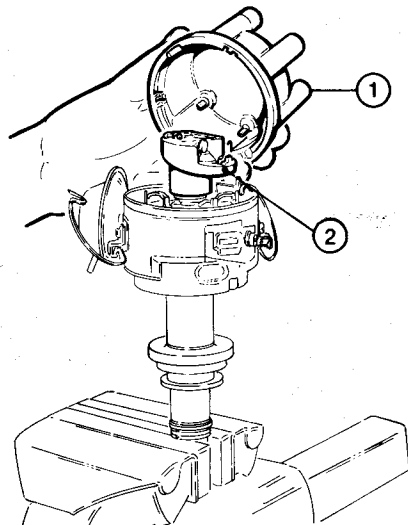

- 1. Distributor cap
- 2. Rotor arm with rpm limiter device

b. Proceeding as shown below, take off retaining ring ① from timer ② and retrieve the washer below.

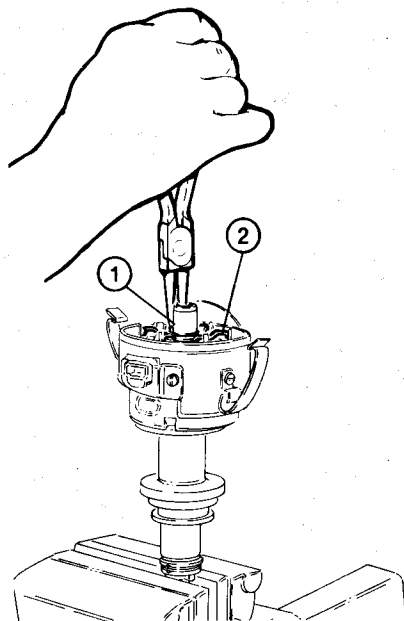

- 1. Retaining ring
- 2. Timer

c. Back off screws ① and remove distributor cap springs ②. Back off screws ③ retaining advance device ④ to distributor body.

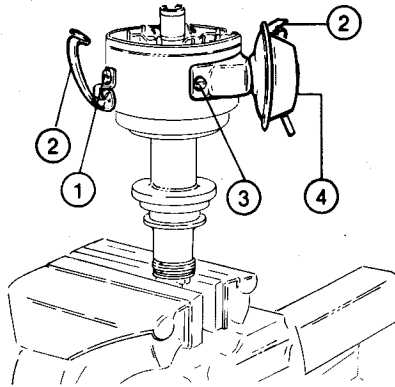

- 1. Spring retaining screw
- 2. Spring
- 3. Advance device retaining screw
- 4. Advance device

d. Remove connector ② from distributor body by backing off screw ①.

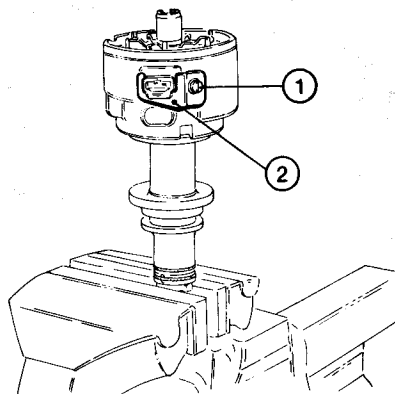

- 1. Connector retaining screw
- 2. Connector

e. Remove timer ① from distributor shaft and retrieve the associated drive roller ② as shown.

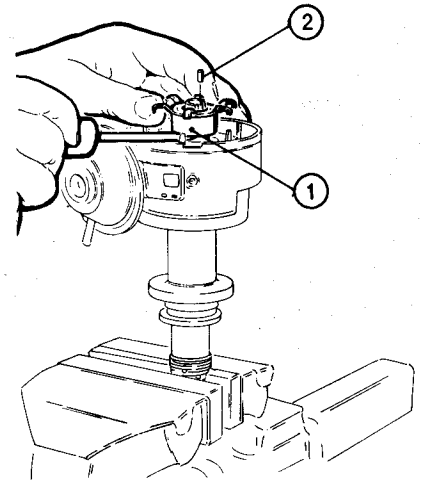

- 1. Timer
- 2. Drive roller

f. Remove advance device ① releasing it from the field winding.

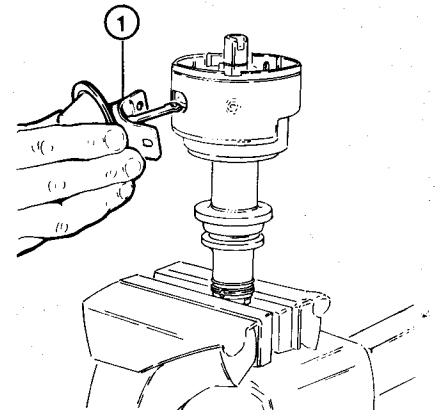

- 1. Advance device

BOSCH DISTRIBUTOR

2.0 iniezione

1.8 turbo

Clamp distributor in a vice provided with soft jaw liners.

- a. Remove cap ① from distributor body.

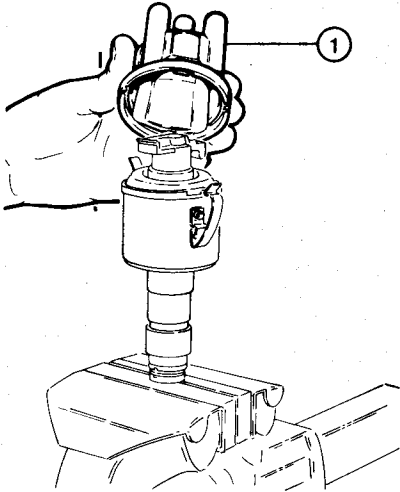

1. Cap

- b. Remove rotor arm ① and dust cover ② from distributor shaft.

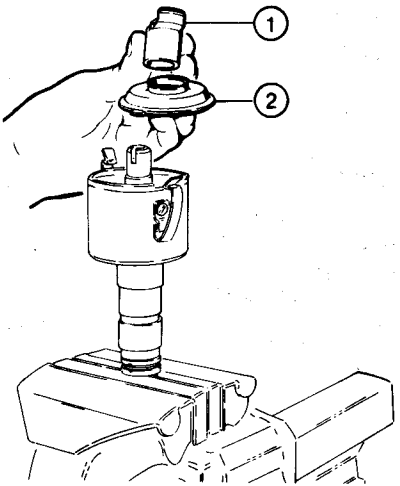

1. Rotor arm
2. Dust cover

INSPECTION

1.6 1.8 2.0 2.5 iniezione

Using a suitable feeler gauge check the air gap between pulse generator ② and timer ①.

Gap S should be as specified.

4-CYLINDER DISTRIBUTOR

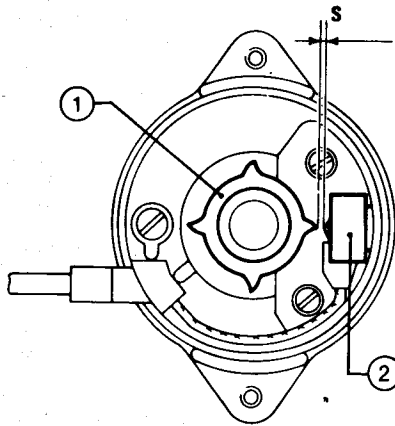

Gap S:

0.5 to 0.6 mm (0.020 to 0.024 in)
(model SM802BX)

- 1. Timer
- 2. Pulse generator

6-CYLINDER DISTRIBUTOR

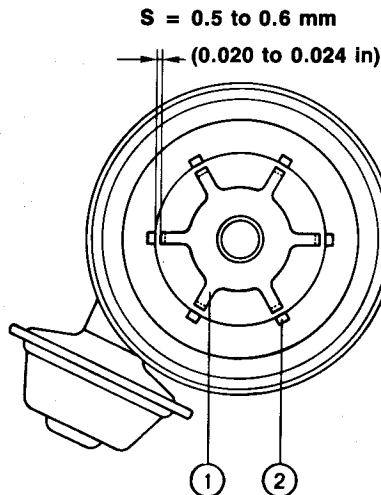

- 1. Timer
- 2. Pulse generator

ASSEMBLY

To assembly reverse the disassembly procedure, noting the following points:

- a. Lubricate the following components using distributor grease:
 - Flyweight springs
 - Flyweights
- b. Moisten distributor shaft felt with a few drops of oil.

NOTE:

Marelli distributor

Whenever the magnetic pulse generator is removed or replaced remember to insert the magnetic spacer on installation.

BENCH TEST

1.6 1.8 2.0 2.5 iniezione

- a. Vacuum advance

- Install distributor on tester and establish the necessary connections.
- Zero the spark on angle dial on tester turning distributor by hand or through tester motor.
- Do not exceed 50 rpm.
- Connect vacuum pipe to tester vacuum gauge.
- Read advance curve in a condition of increasing vacuum (see: Inspection Specifications).
- If the curve obtained is not as specified, replace vacuum advance device.

- b. Centrifugal advance

- Carry out the first two operations specified for vacuum advance test.
- With vacuum advance device disconnected from tester, read automatic advance curve at increasing rpm rate (see: Inspection Specifications).
- If advance characteristics are not as specified, inspect distributor with particular reference to flyweights and springs, timer and pulse generator. Replace any inefficient components.

ON-VEHICLE DISTRIBUTOR INSTALLATION

1.6 1.8 2.0

To install the ignition distributor on the engine proceed as follows:

a. Turn the crankshaft to bring piston number 1 on compression stroke, i.e. with both valves closed.

To this end, turn crankshaft pulley (1) so that reference mark «F» stamped on the pulley, lines up with reference pointer (2) attached to water pump.

b. Remove the cap and install the distributor in the engine front cover.

Insert drive coupling (3) in the groove provided on the spigot of oil pump (4).

c. Position the distributor correctly by suitably rotating it until reference mark (5) on the edge of distributor body lines up with the centerline of rotor arm (6) as shown.

d. Fasten the distributor in this position through the clamp provided.

e. Install cap on distributor and connect the spark plug leads in the correct ignition sequence (1-3-4-2).

f. Carry out ignition timing using a stroboscopic lamp.

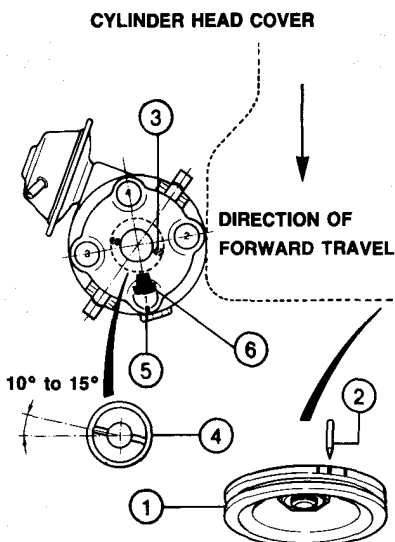

1. Crankshaft pulley
2. Reference pointer
3. Drive coupling
4. Oil pump spigot
5. Reference mark
6. Rotor arm

ON-VEHICLE DISTRIBUTOR INSTALLATION

2.0 (iniezione)

To install the ignition distributor on the engine proceed as follows:

a. Turn crankshaft to bring piston number 1 on compression stroke, i.e. with both valves closed.

To this end, turn crankshaft pulley (1) so that reference mark «F», stamped on pulley, lines up with reference pointer (2) attached to water pump.

b. Remove the cap and install distributor on front engine cover.

Insert drive coupling (3) in the groove on the spigot of oil pump (4).

c. Correctly position the distributor turning it until reference mark (5) on the edge of the body lines up with the centerline of rotor arm (6) as shown.

d. Fasten the distributor in this position using the clamp provided.

e. Install the cap on the distributor and connect the spark plug leads in the correct sequence (1-3-4-2).

f. Warm up engine and check with a stroboscopic gun that at 900 ± 50 rpm idle speed, ignition occurs with reference mark «F» ($10^\circ \pm 1^\circ$ before T.D.C.) aligned to the pointer.

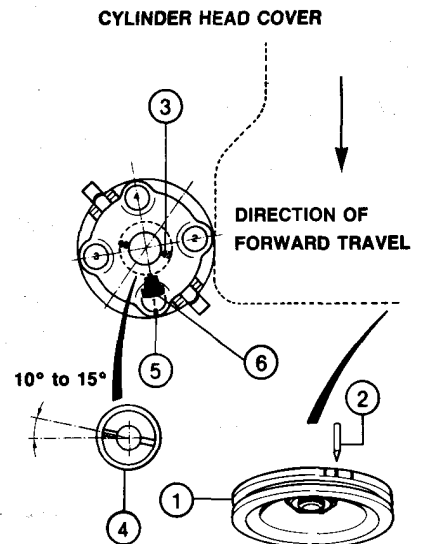

1. Crankshaft pulley
2. Reference pointer
3. Drive coupling
4. Oil pump spigot
5. Reference mark
6. Rotor arm

CAUTION:

The system does not require and does not permit any ignition advance adjustment.

Therefore, **DO NOT TURN** the distributor, otherwise the ignition sequence might be altered with extremely serious consequences.

ON-VEHICLE DISTRIBUTOR INSTALLATION

Alfa 75 1.3 turbo

To install the ignition distributor on the engine proceed as follows:

a. Turn crankshaft to bring piston number 1 on compression stroke, i.e. with both valves closed.

To this end, turn crankshaft pulley ① so that reference mark «F», stamped on pulley, lines up with reference pointer ② attached to the water pump.

b. Remove the cap and install distributor on front engine cover.

Insert drive coupling ③ in the groove on the spigot of oil pump ④.

Ensure that the reference mark is facing as indicated in the figure.

c. Position the distributor correctly by suitably rotating it until connection point ⑤ for supply cable connector lines up with the centreline of rotor arm ⑥ as shown.

d. Fasten the distributor in this position using the clamp provided.

e. Install the cap on the distributor and connect the spark plug leads in the correct sequence (1-3-4-2).

f. Warm up engine and check with a stroboscopic gun that at 900 ± 50 rpm idle speed, ignition occurs with reference mark «F» (9° before T.D.C.) aligned to the pointer.

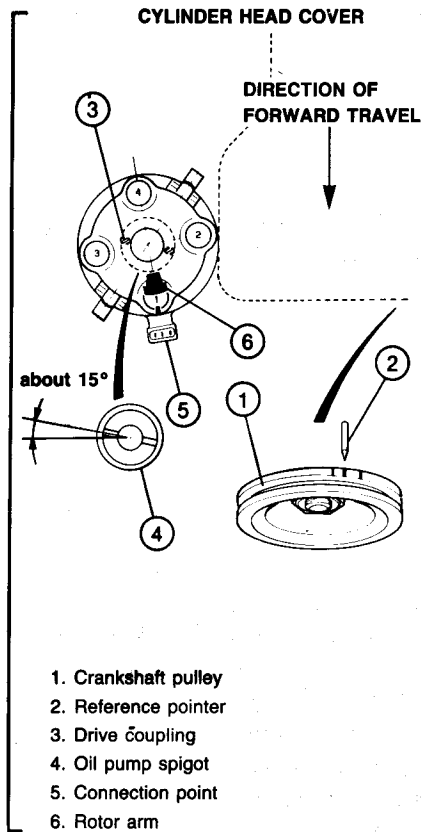

e. Install cap on distributor and connect the spark plug leads in the correct ignition sequence (1-4-2-5-3-6).

f. Carry out ignition timing using a stroboscopic lamp.

CAUTION:

The distributor rotor arm is provided with a rpm limiter that cuts off ignition when the engine speed exceeds 6300 ± 150 rpm.

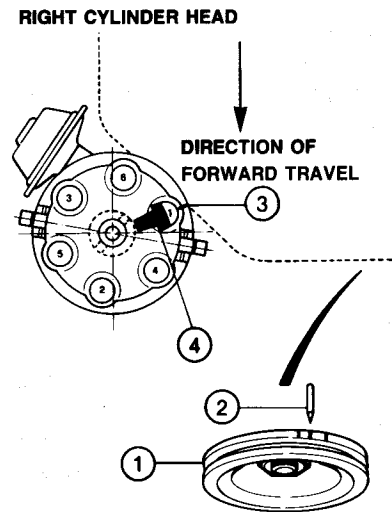

ON-VEHICLE DISTRIBUTION INSTALLATION

2.5 iniezione

To install the ignition distributor on the engine proceed as follows:

a. Turn the crankshaft to bring piston number 1 on compression stroke, i.e. with both valves closed.

To this end, turn crankshaft pulley ① so that reference mark «F» stamped on the pulley, lines up with reference pointer ②

b. Remove the cap and install the distributor with the rotor arm pointing toward cylinder number 1.

c. Position the distributor correctly by suitably rotating it until reference mark ③ on the edge of distributor body lines up with the centerline of rotor arm ④ as shown.

d. Fasten the distributor in this position through the clip provided.

ENGINE IGNITION, STARTER, CHARGING

INSPECTION SPECIFICATIONS

IGNITION DISTRIBUTOR **Alfa 75** **Alfa 90** **Alfetta** **GTV 6 2.5**

Distributor	Alfa Romeo Part No.	116.97.05.011.00	115.44.05.011.00 (1)	116.97.05.011.01	116.46.05.011.00 (2)
	Type	BOSCH 0.237.002.018	BOSCH 0.237.501.002 (1)	MARELLI SM802BX	BOSCH 0.237.301.008 (2)
Firing order		1-3-4-2			1-4-2-5-3-6
Pulse generator coil resistance	Ω	1000 ± 5%	—	730 ± 5%	—
Rotor arm internal resistance	Ω	1000 ± 0.2	—	5000 ± 1	—
Gap	mm (in)	—	—	0.5 to 0.6 (0.020 to 0.024)	—

(1) Distributor fitted to engine 017.13 (Motronic)

(2) Distributor fitted to engine 016.46 (2500)

IGNITION DISTRIBUTOR **Giulietta** **GTV 2.0**

Distributor	Alfa Romeo Part No.	116.55.05.011.00	116.55.05.011.01	116.55.05.011.03
	Type	BOSCH 0.231.170.229	MARELLI S168BX	DUCELLIER 4533A
Firing order		1-3-4-2		
Pulse generator coil resistance	Ω	—	—	—
Rotor arm internal resistance	Ω	≥ 4500	5000 ± 1	5000
Contact gap	mm (in)	0.35 (0.014)	0.37 to 0.43 (0.015 to 0.017)	0.35 (0.014)
Contact dwell angle		62° ± 3°	55° ± 3°	57° ± 3°
Contact load	g (oz.)	500 (17.6)	475 ± 50 (16.7 ± 1.8)	450 ± 50 (15.8 ± 1.8)

Distributor	Alfa Romeo Part No.	116.97.05.011.01 (1)	116.97.05.011.00 (1)	
	Type	MARELLI SM802BX	BOSCH 0.237.002.018	
Firing order		1-3-4-2		
Pulse generator coil resistance	Ω	730 ± 5%	1000 ± 5%	
Rotor arm internal resistance	Ω	5000 ± 1	1000 ± 0.2	
Gap	mm (in)	0.5 to 0.6 (0.020 to 0.024)	0.5 to 0.6 (0.020 to 0.024)	

(1) Distributor fitted to electronic ignition engines

ECU

Supply voltage 4 to 16 V

Max. current 6 A

Heat sink temperature gauge -30 to +125°C (-22 to +257°F)

ENGINE IGNITION, STARTER, CHARGING

IGNITION ADVANCE

Advance (1)	Engines			
	016.00 - 016.78 - 016.55 061.00 - 062.02 - 062.12	017.13	016.46	061.34
Static advance (2)	7° ± 1° B.T.D.C. at idle	10° ± 1° B.T.D.C. at idle	7° ± 1° B.T.D.C. at idle	9° B.T.D.C. at idle
Max. advance (3)	38° $\begin{smallmatrix} +0^\circ \\ -3^\circ \end{smallmatrix}$ B.T.D.C. at 5100 rpm	—	31° $\begin{smallmatrix} +0^\circ \\ -3^\circ \end{smallmatrix}$ B.T.D.C. at 5100 rpm	—

(1) Check static and max. advance with distributor vacuum pipe disconnected

(2) Static advance position: Align pointer to ref. mark «F»

(3) Max. advance position: Align pointer to ref. mark «M»

AUTOMATIC AND VACUUM ADVANCE CURVES

BOSCH 0.237.002.018

Speed (rpm)	Auto. advance curve		Vacuum mmHg (inHg)	Vacuum advance curve	
	Max.	Min.		Max.	Min.
100	15'	1°30'	0 (0)	30'	—30'
230	—30'	45'	60 (2.36)	45'	—30'
280	0°	0°	90 (3.54)	2°	—30'
330	15'	—45'	101 (3.98)	2°45'	—30'
380	0°	—1°	150 (5.91)	6°	3°
470	1°	—1°15'	195 (7.68)	8°30'	5°45'
900	6°	3°30'	210 (8.27)	8°45'	6°30'
1900	11°15'	9°	225 (8.86)	8°45'	6°45'
2500	15°15'	12°45'	300 (11.81)	8°45'	6°45'
2700	15°30'	13°30'			
3000	15°	13°			

BOSCH 0.231.170.229

Speed (rpm)	Auto. advance curve		Vacuum mmHg (inHg)	Vacuum advance curve	
	Max.	Min.		Max.	Min.
150	Start	Start	0 (0)	30'	—30'
200	30'	—30'	50 (1.97)	30'	—30'
400	30'	—30'	100 (3.94)	4°15'	—30'
550	2°30'	—30'	212 (8.35)	9°45'	6°45'
800	5°45'	2°15'	320 (12.60)	9°45'	6°45'
1000	7°30'	4°30''			
1500	10°	7°			
2550	16°30'	13°30'			
3000	16°30'	13°30'			

ENGINE IGNITION, STARTER, CHARGING

BOSCH 0.237.301.008

Speed (rpm)	Auto. advance curve		Vacuum mmHg (inHg)	Vacuum advance curve	
	Max.	Min.		Max.	Min.
100	-15'	45'	0 (0)	30'	-30'
300	-30'	30'	90 (3.54)	30'	-30'
350	-15'	-15'	105 (4.13)	1°	-30'
400	15'	-45'	128 (5.04)	2°30'	-30'
450	15'	-45'	165 (6.50)	5°	2°15'
600	2°15'	-10'	180 (7.09)	5°45'	3°15'
1300	10°45'	8°	196 (7.72)	6°	4°
1500	12°	9°45'	300 (11.81)	6°	4°
1900	13°30'	11°30'			
2100	14°	12°			
2400	13°45'	11°45'			
3000	13°	11°			

MARELLI SM802BX

Speed (rpm)	Auto. advance curve		Vacuum mmHg (inHg)	Vacuum advance curve	
	Max.	Min.		Max.	Min.
250	0°	0°	0 (0)	30'	-30'
300	15'	-15'	40 (1.58)	30'	-30'
450	30'	-1°	100 (3.94)	2°30'	-30'
550	1°30'	-30'	212 (8.35)	9°45'	6°45'
800	4°15'	2°	300 (11.81)	9°45'	6°45'
1000	6°15'	4°30''			
1900	11°30'	9°			
2550	15°30'	13°30'			
3000	15°15'	13°15'			

MARELLI S168BX

Speed (rpm)	Auto. advance curve		Vacuum mmHg (inHg)	Vacuum advance curve	
	Max.	Min.		Max.	Min.
150	Start	Start	0 (0)	30'	-30'
200	45'	-30'	70 (2.76)	30'	-30'
450	45'	-30'	100 (3.94)	2°30'	-30'
550	2°45'	-30'	212 (8.35)	9°45'	6°45'
700	6°	1°30'	320 (12.60)	9°45'	6°45'
800	7°	2°45''			
1000	8°15'	5°15'			
2550	16°30'	13°30'			
3000	16°30'	13°30'			

ENGINE IGNITION, STARTER, CHARGING

DUCELLIER 4533A

Speed (rpm)	Auto. advance curve		Vacuum mmHg (inHg)	Vacuum advance curve	
	Max.	Min.		Max.	Min.
150	Start	Start	0 (0)	30'	-30'
200	45'	-30'	70 (2.76)	30'	-30'
450	45'	-30'	100 (3.94)	2°30'	-30'
550	2°45'	-30'	212 (8.35)	9°45'	6°45'
700	6°	1°30'	300 (12.60)	9°45'	6°45'
800	7°	2°45'			
1000	8°15'	5°15'			
2550	16°30'	13°30'			
3000	16°30'	13°30'			

IGNITION COIL Alfa 75 Alfa 90 Alfetta GTV 6 2.5

Coil	Alfa Romeo Part No.	116.97.65.079.00 (1)	195.00.65.079.00 (2)	116.55.65.079.02 (1)	
	Type	BOSCH 0.221.600.002	BOSCH 0.221.122.344	MAGNETI MARELLI BAE207B	
Primary winding resistance [at 20°C (68°F)]	Ω	0.7 to 1	0.5 ± 10%	0.72 ± 10%	
Secondary winding resistance [at 20°C (68°F)]	Ω	6700 to 9600	6000 ± 10%	7900 ± 10%	

(1) Coil with ECU

(2) Coil fitted to engine 017.13 (Motronic)

IGNITION COIL Giulietta

Coil	Alfa Romeo Part No.	105.26.65.079.00	116.42.65.079.00	105.48.65.079.00	105.12.65.079.02
	Type	BOSCH 0.221.119.008	MARELLI BE200H	KLITZ G53SB	SEV MARCHAL 3H
Primary winding resistance [at 20°C (68°F)]	Ω	2.9 to 3.4	3.14 ± 4%	2.9 to 3.2	>3
Secondary winding resistance [at 20°C (68°F)]	Ω	6000 to 10000	9400 ± 10%	5400 to 8000	5250 to 6000

Coil	Alfa Romeo Part No.	105.12.65.079.03	105.12.65.079.01	116.33.65.079.00	116.55.65.079.01
	Type	ISKRA ATA-0105	DUCELLIER 2792A	MARELLI BZR202B	BOSCH 0.221.119.044
Primary winding resistance [at 20°C (68°F)]	Ω	3.2	2.8 to 3.4	1.70 ± 4% (1)	1.7 to 2.2 (2)
Secondary winding resistance [at 20°C (68°F)]	Ω	6740	6000 to 10000	8500 ± 10%	7000 to 12000

Coil	Alfa Romeo Part No.	116.55.65.079.02 (3)	—		
	Type	MARELLI BAE207B	BOSCH (3) 1.227.020.010		
Primary winding resistance [at 20°C (68°F)]	Ω	0.72 ± 10%	0.82		
Secondary winding resistance [at 20°C (68°F)]	Ω	7900 ± 10%	8.25		

(1) Fitted to 2000 engine (016.55) r = 0.8 ± 10%

(2) Fitted to 2000 engine (016.55) r = 0.9 ± 5%

(3) Coil with ECU fitted to electronic ignition engine

ENGINE IGNITION, STARTER, CHARGING

IGNITION COIL (GTV 2.0)

Coil	Alfa Romeo Part No.	116.55.65.079.00	116.33.65.079.01	116.55.65.079.01	116.55.65.079.02 (3)
	Type	BOSCH 0.221.119.044	MARELLI BZR202B	BOSCH 0.221.119.044	MARELLI BAE207B
Primary winding resistance [at 20°C (68°F)]	Ω	1.7 to 2.2	1.70 ± 4% (1)	1.7 to 2.2 (2)	0.72 ± 10%
Secondary winding resistance [at 20°C (68°F)]	Ω	7000 to 12000	8500 ± 10%	7000 to 12000	7900 ± 10%

Coil	Alfa Romeo Part No.	116.97.65.079.00 (3)	
	Type	BOSCH 0.221.600.002	
Primary winding resistance [at 20°C (68°F)]	Ω	0.7 to 1	
Secondary winding resistance [at 20°C (68°F)]	Ω	6700 to 9600	

(1) Resistance $r = 0.8 \pm 10\%$

(2) Resistance $r = 0.9 \pm 5\%$

(3) Coil with ECU fitted electronic ignition engine

SPARK PLUGS

Alfa Romeo Part No.	105.14.05.106.01	119.00.05.106.01 (1)	— (2)
Type	LODGE 2 HL	SILVER LODGE 2 HL-E	TURBO LODGE 25XL

(1) Spark plug fitted to engines 017.13 (Motronic), 062.10 and 016.46 (2500)

(2) Spark plug fitted to engine 061.34 (1800)

FLUID AND LUBRICANTS

Description	Type	Type of product	Quantity
Spark plug thread	OIL	ISECO Molykote A Part No. 4500-18304	As required

TIGHTENING TORQUES

Description	Unit of measure		
	Nm	kgm	ft.lb
Spark plug (wet, ISECO Molykote A)	25 to 34	2.5 to 3.5	18.4 to 25.1

ENGINE IGNITION, STARTER, CHARGING

TROUBLESHOOTING

Defect	Probable Cause	Remedy
Engine misfires	<ul style="list-style-type: none"> • Erratic HT connections • Ignition coil cap sparking or burnt • Distributor cap sparking or burnt • Rotor arm sparking or burnt • Coil secondary S/C or O/C (coil sparks weak) • Mechanical fault in distributor (visually check for gap between rotor and stator) • Pulse generator resistance inside distributor not as specified • Incorrect ignition timing • Defective fuel supply system • Defective ECU 	<p>Replace or fasten HT connections</p> <p>Replace coil</p> <p>Replace distributor cap</p> <p>Replace rotor arm</p> <p>Replace coil</p> <p>Disassemble distributor and replace defective parts. If necessary, replace entire distributor</p> <p>Replace pulse generator coil</p> <p>Check and adjust ignition timing</p> <p>Remedy as necessary</p> <p>Replace ECU</p>
Engine will not fire	<ul style="list-style-type: none"> • Connections O/C • Ignition coil cap burnt through by HT or grounded • Distributor cap burnt through by HT or grounded • Rotor arm burnt through or grounded • Coil primary S/C or grounded • Coil secondary O/C • Distributor gap incorrect 	<p>Trace and rectify O/C or replace connections</p> <p>Replace ignition coil</p> <p>Replace ignition distributor cap</p> <p>Replace rotor arm</p> <p>Replace ignition coil</p> <p>Replace ignition coil</p> <p>Disassemble distributor and replace any defective parts</p>

IGNITION COIL

6 cylinders **Alfa 90** **20** **iniezione**

DESCRIPTION

Closed core coil is characterized by reduced primary winding resistance and inductance.

Because of this, primary current signal must be strictly controlled in terms of both peak and RMS values.

Control is effected directly by ECU, which also regulates charging time as a function of engine rpm rate, thereby providing optimum spark power characteristics.

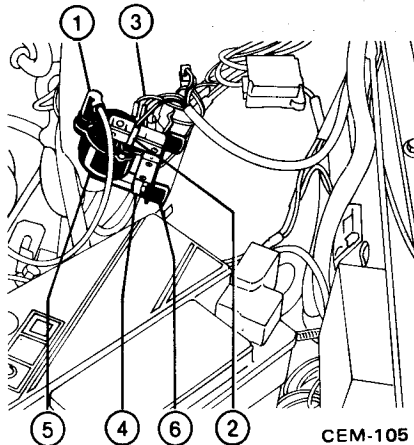

1. HT lead
2. Coil secondary lead
3. Coil primary lead
4. Retaining nuts
5. Coil
6. Cushion pads

ELECTRICAL TESTS

- a. Connect a voltmeter across ground and coil positive 15.
- b. Turn ignition key to ON position and check for +12 V signal.
- c. Turn off ignition key and, using the ohmmeter, check for open circuits across coil negative 1 and pin 35 of WHITE connector on ECU.
- d. Disconnect conductors from coil.
- e. Using the ohmmeter, check that secondary resistance across positive 15 and HT terminal is **3.7 Ohm ±10%**.
- f. Using the ohmmeter, check that primary resistance across positive 15 and negative is virtually nil (**0.344 Ohm**).

INSTALLATION

For installation adopt a reversal of the removal sequence, and note the following points:

- Interpose **new cushion pads** between coil and vehicle left side wall.
- Ensure that HT and primary and secondary winding connectors are tight.

REPLACEMENT

- a. Disconnect battery negative terminal.
- b. Disconnect HT lead (1) from coil.
- c. Disconnect lead (2) from positive coil secondary terminal 15.
- d. Disconnect leads (3) from negative coil primary terminal 1.
- e. Back off nuts and washers (4) retaining coil to vehicle left side wall.
- f. Remove coil (5) and two cushion pads (6).

SPECIFICATIONS

MASTER RESET SENSOR

A

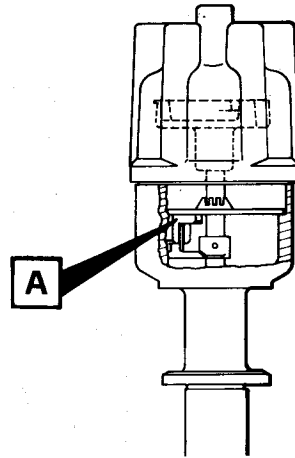
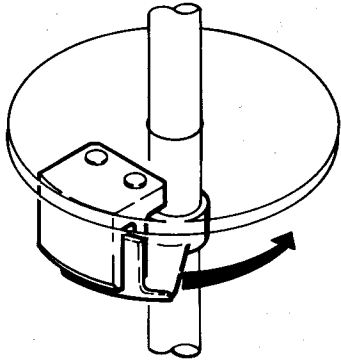

Description	Unit of measure
Supply voltage (d.c.)	5 V ± 0.25 V
Max. permissible load	40 mA
Signal initiation (advance angle relative to TDC cylinder No. 1)	113°
Signal on angle	23° to 31°
Low voltage level (I ≤ 10 mA)	≤ 0.4 V
High voltage level (I ≤ 10 μA)	3.5 to 5 V

DISTRIBUTOR

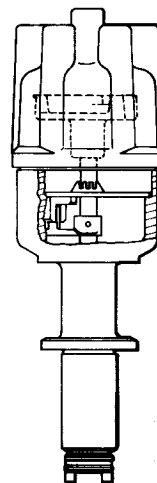
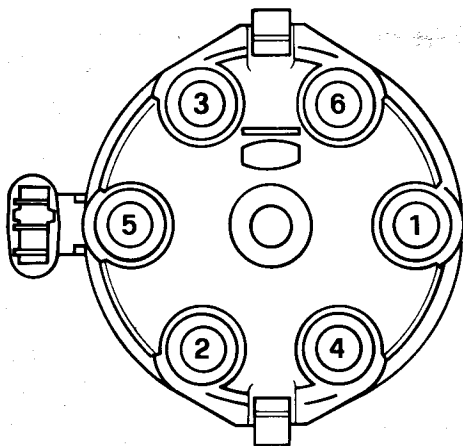

Distributor	Alfa Romeo Part No.	195.15.05.011.00 (1)
	Type	MARELLI DT 454A
Firing order		1-4-2-5-3-6

(1) Distributor with integral master reset sensor